



Pall Corporation

FBSFGEN

Filter Housings

For use in Food
and Beverage Production



Filtration. Separation. Solution.SM

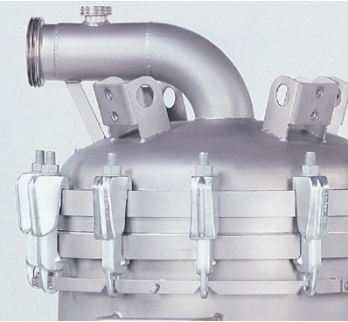

Filter Housings

'Inverted Filter Orientation'

For use in Food and Beverage production

This range of Pall® filter housings has been designed and engineered to meet the demands of Food and Beverage applications such as beer, wine, spirits, soft drinks, and bottled water.

All product contact components are manufactured from corrosion resistant 316L stainless steel. Each housing has an electropolished internal finish throughout to ensure hygienic operation.

The range includes options to accommodate from eight to forty four bayonette locking, double o-ring seal filters. The extensive range of **Pall** filters can be incorporated to provide the optimum combination for specific filtration applications.

Features and Benefits

- Inverted filter design
- Large inlet and outlet connections allow high flow rates with low differential pressures.
- Electropolished internally to ensure smooth and easy to clean surfaces.
- Large vent and drain connections which aid emptying and rapid cartridge changeout.
- High security closures ensure safe operation at high pressures.

Dimensions

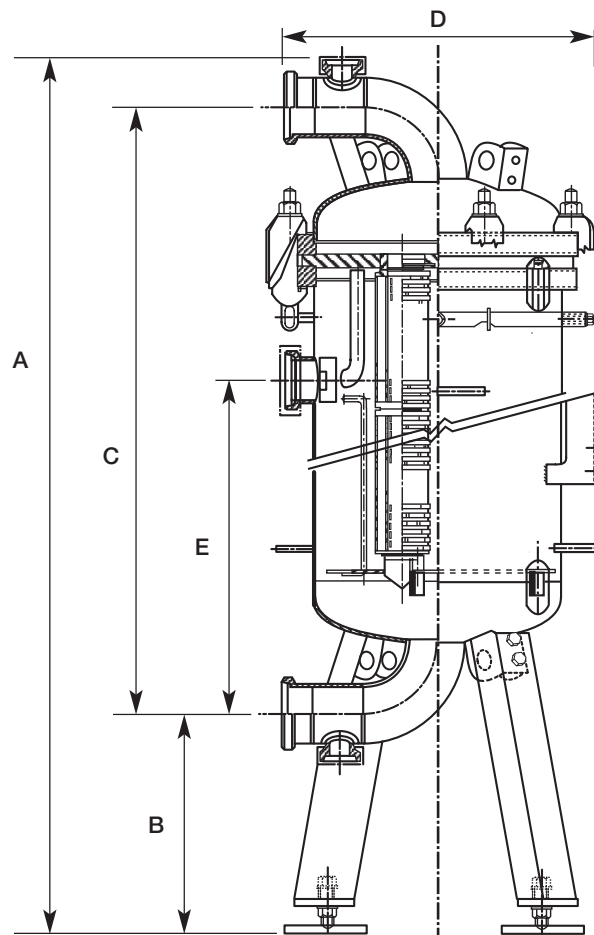

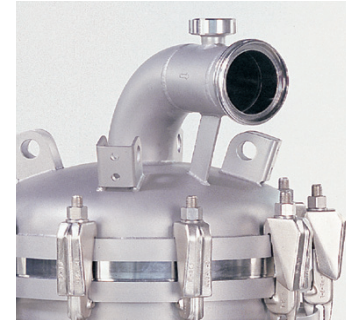

Technical Information

Dimensions*

Housing	Nominal Dimensions in mm				
	A	B	C	D	E
SFG7083GNW50	1470	290	1120	352	782
SFG7084GNW50	1720	290	1370	352	1032
SFG7123GNW65	1521	290	1164	400	806
SFG7124GNW65	1769	290	1412	400	1054
SFG7193GNW80	1594	284	1236	500	840
SFG7194GNW80	1842	284	1484	500	1089
SFG7313GNW80	1653	290	1289	600	861
SFG7314GNW80	1901	290	1537	600	1109
SFG7443GNW100	1765	252	1428	720	928
SFG7444GNW100	2013	252	1676	720	1176

*Sufficient height above the housing for cartridge removal should be allowed.

Specification

Maximum operating pressure	10 barg (145.03psig)
Maximum operating temperature	140°C (284°F)
Materials of construction	Head and bowl 316L stainless steel Legs and clamps 304 stainless steel O Ring seal ethylene propylene ¹
Surface finish	External - Glass Bead Internal - Electropolished
Standard vent/drain connections	25mm DIN 11851 Male. For other options please contact Pall
Filter cartridge compatibility	Pall AB code 7 filter cartridges
Design specification	Design capability of 5 times maximum operating pressure. Each housing hydrostatically tested to 1.3 times maximum operating pressure.

Please refer to Pall Food and Beverage filter cartridge literature for additional guidelines on use.

Approximate Water Flow/Pressure Drop for Food and Beverage Filter Housings

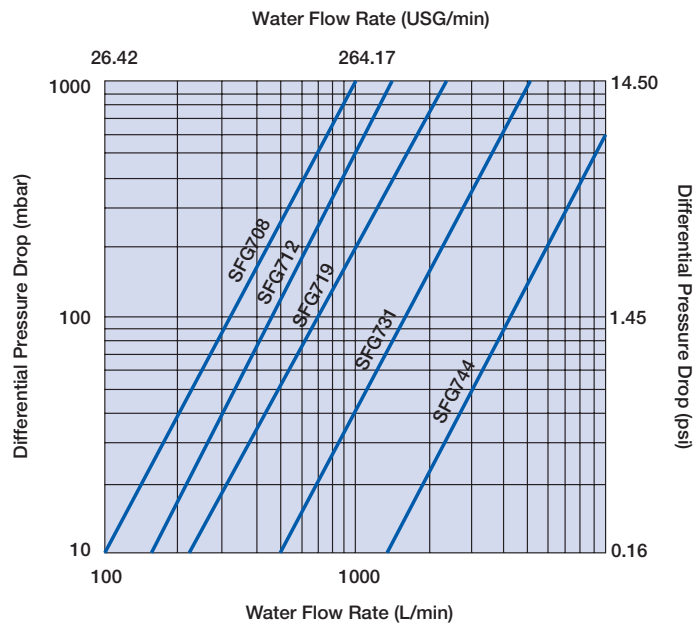

Pressure Drop
The liquid flow/pressure drop characteristics refer to the empty housing only for water at 20°C (68°F). For other liquids, multiply pressure drop by the specific gravity.

Ordering Information

This is a guide to the part number structure and possible options only. For availability of specific options, please contact Pall.

Pall Part Number:

S F G 7   G 

Table 1

Code	Number of Cartridges
08	8
12	12
19	19
31	31
44	44

Table 2

Code	Cartridge Nominal Length
3	762 mm (30")
4	1016 mm (40")

Table 3

Code	Standard Inlet/Outlet Connection
NW50	50 mm DIN 11851 Male
NW65	65 mm DIN 11851 Male
NW80	80 mm DIN 11851 Male
NW100	100 mm DIN 11851 Male

Housing closure seal material - Ethylene Propylene

Accessories

Description	Ordering Reference
Vent/Drain valve	ACS0085CU
80mm DIN stub adaptor kit	ACS0139GA
80mm DIN hosetail adaptor kit	ACS0140GA
Vent, drain, pressure gauge and view glass assembly	ACS0616AU
25mm Blanking Plate	ACS0157AA
50mm Blanking Plate	ACS0840AM
Pressure Gauge (0-10 barg linear)	ACS0867FA

Replacement Parts

Description	Ordering Reference
Rathmann Clamp kit	ACS0006DA
Ethylene Propylene Housing Closure Seal Kit ¹	
SFG708	LS00363
SFG712	ACS0027EX
SFG719	ACS0041EX
SFG731	ACS0052EX
SFG744	ACS0069EX
15mm DIN Seal (2)	ACS0055EU
25mm DIN Seal (2)	ACS0060EU

¹The seal materials employed meet FDA requirements for food contact use as detailed in 21 CFR Section 177.2600



Pall Food and Beverage

Portsmouth - UK
 +44 (0)23 9230 2269 telephone
 +44 (0)23 9230 2509 fax
 processuk@pall.com

New York - USA
 866 905 7255 toll free
 +1 516 484 3600 telephone
 +1 516 625 3610 fax
 foodandbeverage@pall.com

Visit us on the web at www.pall.com

Pall Corporation has offices and plants throughout the world in locations including: Argentina, Australia, Austria, Belgium, Brazil, Canada, China, France, Germany, India, Indonesia, Ireland, Italy, Japan, Korea, Malaysia, Mexico, the Netherlands, New Zealand, Norway, Poland, Puerto Rico, Russia, Singapore, South Africa, Spain, Sweden, Switzerland, Taiwan, Thailand, United Arab Emirates, United Kingdom, United States, and Venezuela. Distributors are located in all major industrial areas of the world.

Because of developments in technology these data or procedures may be subject to change. Consequently we advise users to review their continuing validity annually. Part numbers quoted above are protected by the Copyright of Pall Europe Limited.

 and Pall are trade marks of Pall Corporation.
 Filtration, Separation, Solution, and Total Fluid Management are service marks of Pall Corporation.
 ® indicates a trade mark registered in the USA.
 ©2006, Pall Corporation.