



## Pall Portable Filtration Unit Ultipleat® SRT PFU Series

### Features

- Pall Ultipleat® SRT filtration technology
- Low noise level, compact and portable unit
- Easy element removal from the filter housing
- Flows up to 13 L/min (3.4 USgpm)
- Pressures up to 10 bar (150 psi)
- Inlet connection : 1½" BSP female
- Outlet connection : 1" BSP male

### Notes and Specifications Filtration Unit

Power Consumption:	0.25 kW
Supply Power:	Single phase, 230 V, 50 Hz
Control Box:	On/Off switch
Approximate Dry Weight:	15.75 kg (34.7 lbs)
Fluid Compatibility:	Fluorocarbon elastomer seals. Compatible with petroleum based fluids, synthetics and mineral oils
Viscosity Range:	10 - 320 cSt
Temperature Range:	-10 °C to 70 °C (14 °F to 160 °F)
Maximum Pressure for Outlet:	10 bar (150 psi)
Maximum Negative Pressure for Inlet:	0.4 bar (6 psi)
Materials of Construction:	Aluminium, steel
Filter Element Burst Pressure:	10 bar (150 psid)
Ultipleat SRT Element Construction:	Inorganic fibers impregnated and bonded with epoxy resins. Polymer endcaps. Anti-static media design.



Pall Ultipleat® Filtration Unit

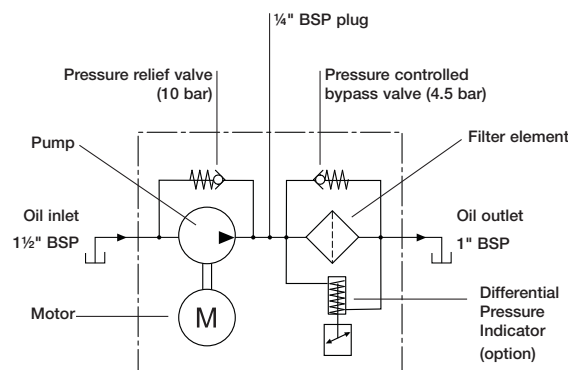
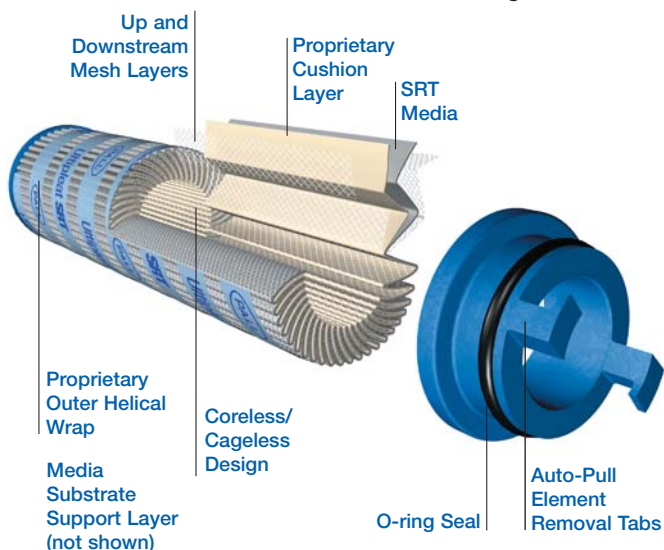

### Element Pressure Drop information

Multiply actual flow rate times factor in table below to determine pressure drop with fluid at 32 cSt (150 SUS), 0.9 S.G. Correct for other fluids by multiplying new viscosity in cSt/32 (SUS/150) x new S.G./0.9. Note: factors are per 1000 L/min and per 1 US gpm.

### 219 Series Filter Elements — bard/1000 L/min (psid/US gpm)

Length Code	AZ	AP	AN	AS	AT
08	9.93 (0.545)	4.21 (0.231)	2.83 (0.155)	1.76 (0.096)	1.33 (0.073)

## Technical Information

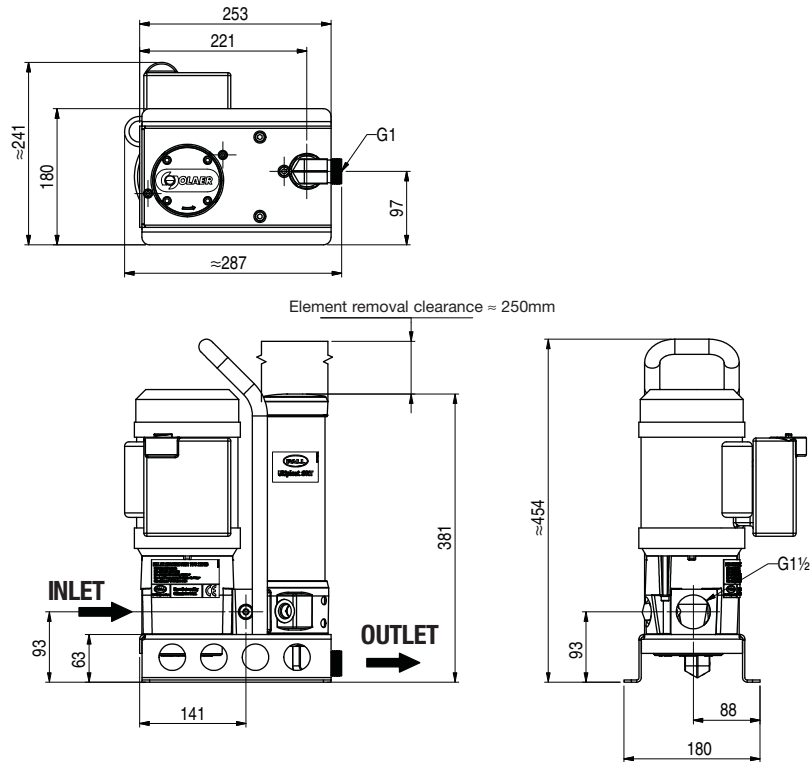

## Ordering Information

Filtration Unit P/N: **PFU11PN5**

Filter Element P/N: **UE 219**   **08 Z**  
Table 1

Indicator P/N: **RC**   **091 Z**  
Table 2

Table 1: Filter Element Options

Code	$\beta_{x(c)} \geq 1000$ Based on ISO 16889	CST Rating*
AZ	3	08/04/01
AP	5	12/07/02
AN	7	15/11/04
AS	12	16/13/04
AT	22	17/15/08

\* CST: Cyclic Stabilization Test to determine filter rating under stress conditions, based on SAE ARP4205

Table 2: Differential Pressure Indicator Options\*

Code	Indicator	'H' Dim.
860MZ	'D' type Visual indicator with no thermal lockout	21 mm (0.83 in)

\* Other indicator options are available; contact Pall.



### Pall Industrial Manufacturing

25 Harbor Park Drive  
 Port Washington, NY 11050  
 +1 516 484 3600 telephone  
 +1 888 333 7255 toll free US

Portsmouth - UK  
 +44 (0)23 9230 3303 telephone  
 +44 (0)23 9230 2507 fax

### Visit us on the Web at [www.pall.com](http://www.pall.com)

Pall Corporation has offices and plants throughout the world. For Pall representatives in your area, please go to [www.pall.com/contact](http://www.pall.com/contact)

Because of technological developments related to the products, systems, and/or services described herein, the data and procedures are subject to change without notice. Please consult your Pall representative or visit [www.pall.com](http://www.pall.com) to verify that this information remains valid. Products in this document may be covered by one or more of the following patent numbers: EP 667,800; EP 982,061; EP 1,380,331; US 5,543,047; US 5,690,765; US 5,725,784; US 6,113,784; US 7,083,564; US 7,318,800.

© Copyright 2010, Pall Corporation. Pall, and Ultipleat are trademarks of Pall Corporation. ® Indicates a trademark registered in the USA. *Filtration. Separation. Solution.<sup>SM</sup>* is a service mark of Pall Corporation.