

Pall PCC81-KC Component Cleanliness Cabinet

The Pall PCC81-KC Cleanliness Cabinet facilitates the accurate, reliable and repeatable preparation of gravimetric membranes for the determination of component cleanliness.

The PCC81-KC enables operators to access the cleanliness level of the manufactured parts and components in accordance to ISO18413, ISO16232 and VDA 19 procedures.

Features

- Large work area for large manufactured parts
- Reliable and repeatable measurements
- HEPA filtered laminar air flow in a self contained super polished stainless steel working area
- Simple to install and operate
- Fully portable requiring only a power source
- Designed and built to ISO Pressure Washing standard 16232
- Solvent dispensing gun with fluid volume dispensing counter
- Pressurized solvent dispensing and recycling circuits
- Gravimetric membrane holder
- Auto Wall Wash function
- PLC controlled operating parameters (option)
- Auto lifting arm for large heavy parts (option)

General Specifications

- Polished stainless steel extraction enclosure
- Controlled cleanliness environment (Class 5 per ISO 14644-1)
- HEPA filter rating: 0.3 μm absolute
- Control panel with colored touch screen
- Solvent filter rating: 0.2 μm absolute
- Test membrane holder in the power zone
- Noise level in working conditions : < 80 dB



PCC81-KC Cleanliness Cabinet



Component cleanliness measurement in a controlled stainless steel environment

Cabinet Option:

- Touch Screen 7" PLC Display (Option)



Design it
Build it
Keep it **CLEAN**

Technical Specifications

- Dimensions: 2100mm W x 1350mm D x 2520mm H
- Power inputs: 220V 50 or 60 Hz, 1 or 3 phase
- Working area: 1660mm W x 1060mm D x 950mm H
- Air flow ISO14644-123 Class 5
- Electric power consumption: 2.5 kW (7A)
- Reservoir : 50 L with fluid level indicator
- Spray rinsing flow rate: 2.5 L/min (adjustable)
- Wall wash flow rate: 0-21 L/min (adjustable)
- Spray rinse pressure: set 5 bar (adjustable)
- Wall wash solvent filter rating 0.2 µm
- Dry weight: about 900Kg
- Membrane holder: 2 stages cascade, 47mm diameter.
- Synthetic hydrocarbon washing fluids
- Vacuum pump pressure: app. -0.87Bar

Technical Drawing

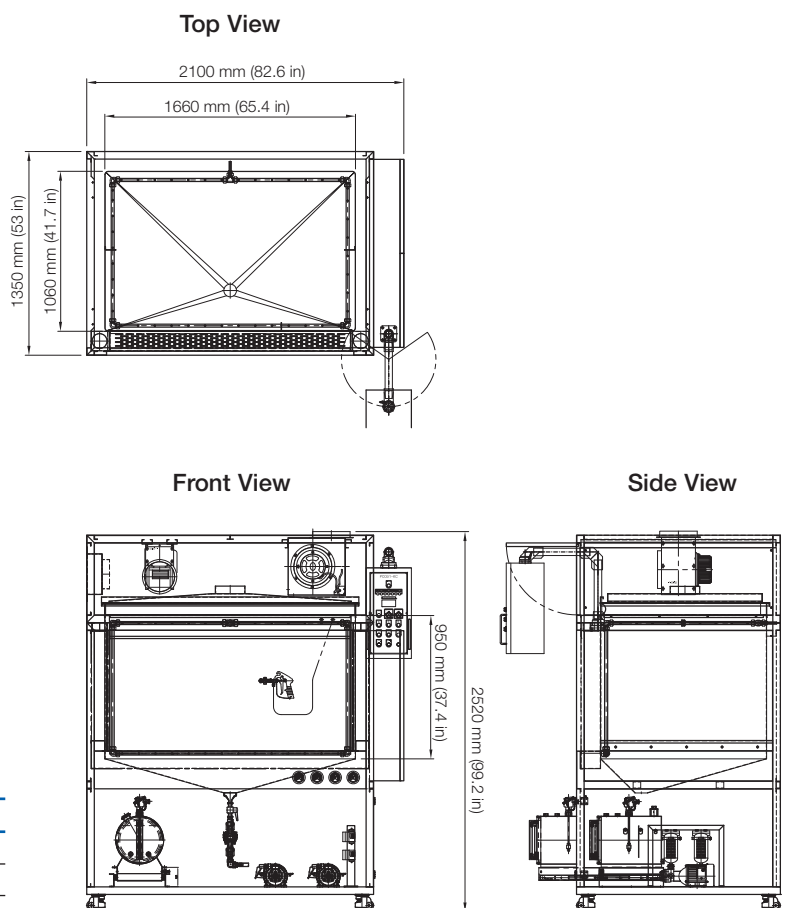

Ordering information

Component Cleanliness Cabinet

PCC81-KC 1 2 3

Table 1: Options

Code	Description
Omit	Standard
T5	Touch Screen PLC - 5" size
T7	Touch Screen PLC - 7" size

Table 2: Options

Code	Description
S	Shower Nozzle Line Addition
P	Air Purge and Shower Nozzle Line Addition

Table 3: Accessories

Code	Description
90	90kgf Auto Lift Arm
150	150kgf Auto Lift Arm
250	250kgf Auto Lift Arm

Other options available on application.



Pall Corporation

Pall Machinery & Equipment

25 Harbor Park Drive
Port Washington, NY 11050
+1 516 484 3600 telephone
+1 800 289 7255 toll free US

Pall Korea, 968-5 Ildong Building,
Daechi-Dong Gangnam-Gu,
Seoul, Korea
+ 82-2-560-7826 telephone
+ 82-2-569-9092 fax

Filtration. Separation. Solution.SM



ENABLING A
GREENER
FUTURE.SM

Visit us on the Web at www.pall.com

Pall Corporation has offices and plants throughout the world. For Pall representatives in your area, please go to www.pall.com/contact

Because of technological developments related to the products, systems, and/or services described here in, the data and procedures are subject to change without notice. Please consult your Pall representative or visit www.pall.com to verify that this information remains valid.

© Copyright 2012, Pall Corporation. Pall and are trademarks of Pall Corporation. © indicates a trademark registered in the USA. ENABLING A GREENER FUTURE and Filtration. Separation. Solution.SM are service marks of Pall Corporation.