

New: T200 Series Versalon™ Tank Mounted Filters

Versalon™ T200 tank mounted filters deliver high performance contaminant protection for lube and hydraulic systems in an economical package tailored for Industrial and Mobile OEMs. The T200 features Coralon® filter elements, with world-class $\text{Beta}_{X(C)} \geq 1000$ filtration rating.

Notes and Specifications

Filter Housing

- **Maximum Flow Rate (8 inch assembly):**
150 L/min (39 US gpm)
- **Maximum Allowable Working Pressure:**
10 bar (145 psi)
- **Fluid Compatibility:**
Compatible with all petroleum oils, water glycols, water-oil emulsions, and most synthetic hydraulic and lubrication fluids
- **Temperature Range:**
Nitrile Seals: -29°C to 100°C (-20°F to 212°F)
50°C (122°F) maximum in HWCF or water glycol fluids
- **Bypass Valve Settings:**
3.4 bar (50 psi)
- **Visual Gauge Settings:**
Visual gauge with green at <2.4 bar (35 psi) and red >2.4 bar (35 psi)
- **Materials of Construction:**
Head: Aluminum alloy
Cover: Polyamide
Canister: Polyamide

Filter Element

- **Filter Element Collapse Pressure:**
10 bar (145 psid)
- **Filter Element Construction:**
Inorganic fibers impregnated and bonded with epoxy resins.
Corrosion protected carbon steel core and end caps

Pressure Drop Information

Housing pressure drop using fluid with 0.9 S.G.

Housing pressure drop is directly proportional to specific gravity

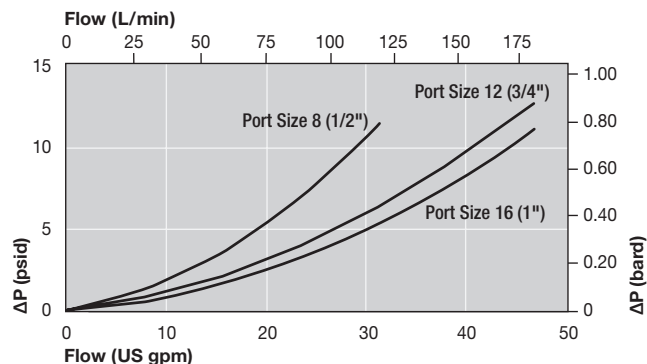

T200 Series Filter Housing

Element Pressure Drop

HCT200 Filter Elements – barg/1000 L/min (psid/US gpm)

Length Code	CS	CT
04	6.0 (0.33)	3.92 (0.21)
08	3.33 (0.18)	2.04 (0.11)

Multiply actual flow rate times factor in table above to determine pressure drop with fluid at 30 cSt (141 SUS), 0.9 S.G. Correct for other fluids by multiplying new viscosity in cSt/30 (SUS/141) x new S.G./0.9.

Note: factors are per 1000 L/min and per 1 US gpm.

Sample ΔP calculation

T200 Series 8 inch length with C16 ports using CS grade media. Operating conditions 100 L/min flow rate using a hydraulic fluid at 45 cSt and specific gravity (s.g.) 1.2

Total Filter ΔP

$$\begin{aligned}
 &= \Delta P_{\text{housing}} + \Delta P_{\text{element}} \\
 &= (0.32 \times 1.2/0.9) \text{ barg (housing)} \\
 &+ ((100 \times 3.3/1000) \times 45/30 \times 1.2/0.9) \text{ barg (element)} \\
 &= 0.43 \text{ barg (housing)} + 0.66 \text{ barg (element)} \\
 &= \mathbf{1.09 \text{ barg (15.8 psid)}}
 \end{aligned}$$

Dimensional Drawings

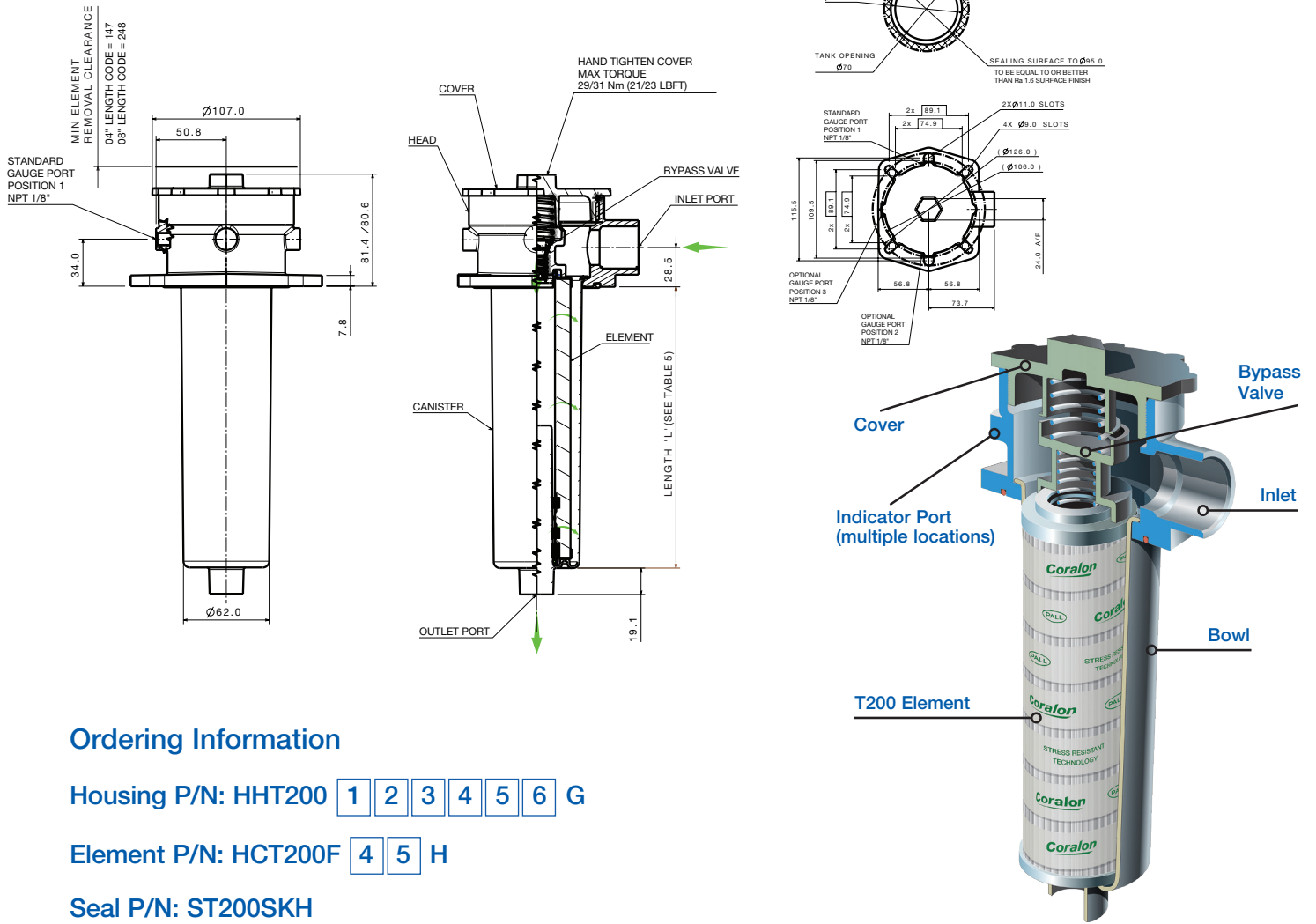

Ordering Information

Housing P/N: HHT200 1 2 3 4 5 6 G

Element P/N: HCT200F 4 5 H

Seal P/N: ST200SKH

Table 1: Housing Port Style Options

Code	Port Style
C	BSP threads to ISO 228
A	SAE J1926 straight thread
U2	JIS B0203 tapered pipe thread

Table 2: Housing Port Size

Code	Port Size
08	1/2"
12	3/4"
16	1"

Table 3: Indicator Port Location

Code	Gauge Position
1	Position 90 degrees counter clockwise from inlet port (standard)
2	Position 90 degrees clockwise from inlet port
3	Position opposite from inlet port

Table 4: Filter Element Options

Code	Rating (μm) $\beta_{10} \geq 1000$
CS	12
CT	22

Table 5: Length Options

Housing Code	Element Code	Length mm (in)
R	04	102 (4)
S	08	203 (8)

Table 6: Bypass Valve

Code	Bypass Valve Type
B	3.4 ± 0.3 bar (49 ± 6 psi)



25 Harbor Park Drive
Port Washington NY 11050
+1 516 484 3600 telephone
+1 800 289 7255 toll free US

Portsmouth - UK
+44 (0)23 9233 8000 telephone
+44 (0)23 9233 8811 fax
industrialeu@pall.com



Visit us on the Web at www.pall.com

Pall Corporation has offices and plants throughout the world. For Pall representatives in your area, please go to www.pall.com/contact

Because of technological developments related to the products, systems, and/or services described herein, the data and procedures are subject to change without notice. Please consult your Pall representative or visit www.pall.com to verify that this information remains valid.

© Copyright 2018, Pall Corporation. Pall, , Coralon and Versalon are trademarks of Pall Corporation.

® Indicates a trademark registered in the USA. Better Lives. Better Planet and *Filtration. Separation. Solution.sm* are service marks of Pall Corporation.