



New: UR629 Series Athalon® Return Line Duplex Filters

Athalon® maximum-life filters deliver the highest level of sustained fluid system protection, across all applications, regardless of severity.

Featuring an industry leading $\beta_{X(C)}=2000^*$ filter efficiency; the highest rated filter performance available today.

(* per ISO 16889)

Notes and Specifications Filter Housing

- Flows to 1500 L/min (400 US gpm)
- Pressures to 28 bar (400 psi)
- Port Size 3" and 4"
- **Rated Fatigue Pressure:**
0-23 bar (330 psi) per NFPA T2.06.01R2-2001 CAT C/90/* (1 million cycles), verified by testing at 0-27 bar (392 psi) for 1 million cycles.
- **Filter Element Burst Pressure:**
10 bard (150 psid)
- **Fluid Compatibility:**
Compatible with all petroleum oils and most water glycols, water-oil emulsions, and most synthetic hydraulic and lubrication fluids
- **Temperature Range:**
Fluorocarbon Seals:
-29° C to 120° C (-20° F to 248° F)
60° C (140° F) maximum in HWCF or water glycol fluids
- **Bypass Valve Setting:**
4.5 bard (65 psid) or
1.7 bard (25 psid)
- **Indicator Pressure Setting:**
3.5 bard (50 psid) or
1.1 bard (16 psid)
- **Materials of Construction:**
Head, tube, manifold and check valve: Aluminium
Cover: Cast iron
- **Filter Element :**
Inorganic fibers impregnated and bonded with epoxy resins.
Polymer endcaps. Anti-static media design

Pressure Drop Information

Housing pressure drop using fluid with 0.9 S.G.

Housing pressure drop is directly proportional to specific gravity.

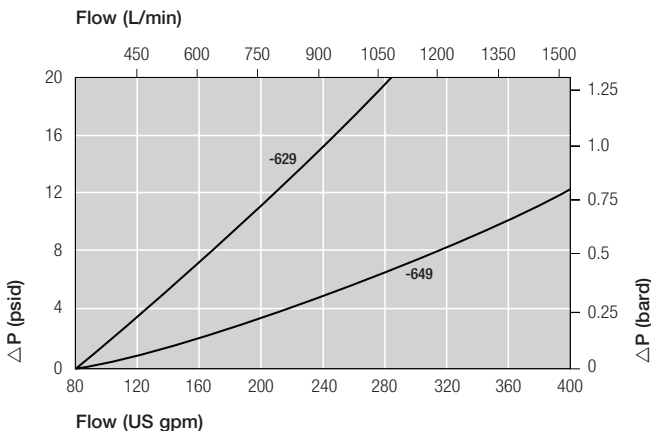

UR629 Series duplex filter housing

- Keeps fluids the cleanest, longest, for the greatest value
- Provides consistent, reliable, protection of system components over the full service life of the filter element
- Rapidly achieves and sustains required fluid system cleanliness
- Delivers maximum filter capacity in the smallest footprint
- Prevents electrostatic discharge from damaging your filter and degrading your fluid

Features

- Patented Ultipleat (laid-over pleat) filter medium pack
- Pall Stress-Resistant Technology (SRT) Media
- Coreless filter element configuration
- Low clean differential pressure for low energy operation

Element Pressure Drop

610 Series Filter Elements – bard/1000 L/min (psid/US gpm)

Length Code	AZ	AP	AN	AS	AT
20	1.31 (0.072)	0.56 (0.030)	0.43 (0.023)	0.31 (0.017)	0.19 (0.011)
40	0.70 (0.038)	0.30 (0.016)	0.23 (0.013)	0.17 (0.009)	0.10 (0.006)

Multiply actual flow rate times factor in table below to determine pressure drop with fluid at 32 cSt (150 SUS), 0.9 S.G. Correct for other fluids by multiplying new viscosity in cSt/32 (SUS/150) x new S.G./0.9. Note: factors are per 1000 L/min and per 1 US gpm

Sample ΔP calculation

UR629 Series 40" length housing with F48 (3" SAE) split flange ports using AN grade media. Operating conditions 600 L/min flow rate using a hydraulic fluid of 50 cSt and specific gravity (s.g.) 1.2.

Total Filter ΔP

$$\begin{aligned}
 &= \Delta P \text{ housing} + \Delta P \text{ element} \\
 &= (0.45 \times 1.2/0.9) \text{ bard (housing)} \\
 &+ ((600 \times 0.23/1000) \times 50/32 \times 1.2/0.9) \text{ bard (element)} \\
 &= 0.60 \text{ (housing)} + 0.29 \text{ bard (element)} \\
 &= \mathbf{0.89 \text{ bard (12.9 psid)}}
 \end{aligned}$$

Ordering Information

For new installations, select one complete part number from each section below

Section 1 Housing P/N: UR 9

Table A Table B Table C

Note: Pall Athalon filter housings are supplied without filter elements or warning devices fitted. Never operate the filter unless a filter element is fitted and all warning device ports are sealed.

Note: Z indicates fluorocarbon seals are standard. Other options are available; contact Pall. Housing P/N designates indicator port fitted with a plastic shipping plug.

Table A	Table B	Table C
No. of Housings	Port & Length Options	Bypass Options
Table 1	Tables 2, 3, 4	Table 5
	D4820Z	
	D4840Z	
	D6420Z	
	D6440Z	
629C	F4820Z	A,G, or N
	F4840Z	
	F6420Z	
	F6440Z	
	D4840Z	
	D6440Z	
649C	F4840Z	A,G, or N
	F6440Z	
	D6440Z	
669C	F6440Z	A or G
	D6440Z	
689C	F6440Z	A or G

Table 1: No. of Filter Housings

Code	No. of Housings
629	2 (1 per side)
649	4 (2 per side)
669	6 (3 per side)
689	8 (4 per side)

Table 2: Housing Port Options

Code	Port Style
D	Flange J518C code 61
F	ISO 6162 split flange

Table 3: Port Size

Code	Port Style
48	3" nominal
64	4" nominal

Table 4: Housing Length and Seal Options

Code	Length and Seal Material
20Z	20" nominal length, fluorocarbon seals
40Z	40" nominal length, fluorocarbon seals

Table 5: Bypass Valve and Service Options

Code	Bypass Valve and Service Type
A	1.7 bard (25 psid) bypass valve, cover service
G	4.5 bard (65 psid) bypass valve, cover service
N	No bypass valve

Seal Kit P/N: UR629CSKZ

*Other seal material options are available; Contact Pall.

Section 2 Element P/N: UE 610

Table 6 Table 3

Note: Z indicates fluorocarbon seals are standard. Other options are available; contact Pall.

Table 6: Filter Element Options

Code	$\beta_{X(c)} \geq 2000$ based on ISO 16889	CST Rating*
AZ	3	07/04/01
AP	5	11/08/03
AN	7	13/09/04
AS	12	15/11/06
AT	25	16/14/08

* CST: Cyclic Stabilization Test to determine filter rating under stress conditions, based on SAE ARP4205

Section 3 (At least one Differential Pressure Indicator or 'B' type blanking plug must be ordered for each filter tower)

Differential Pressure Indicator P/N:

RC Z Z

Table 7 Table 8

Note: If no differential pressure indicator is selected, 'B' type blanking plug (P/N HC9000A104Z) must be ordered separately and fitted to replace the plastic shipping plug in each filter tower.

Note: Z indicates fluorocarbon seals are standard. Other options are available; contact Pall.

For typical installations, only 2 indicators are required - only one housing per side requires an indicator. Replace other shipping plugs with blanking plugs.

Table 7: Indicator Options

Code	Brass Option indicator
A218M	Electrical switch (SPDT) with Hirschmann connector
A218R	Electrical switch (SPDT) with Hirschmann connector with Red and Green LED indicators
A219D	Visual indicator

Other options are available; contact Pall.

Table 8: Indicator Pressue Setting Option

Code	Valve
084	For 'A' Valve Option - Housings (1.1 bard - 16 psid)
091	For 'G' and 'N' Valve Options - Housings (3.5 bard - 50 psid)

Other setting options are available; contact Pall.

Dimensional Drawings

Dimensions in mm (inches)

Contact Pall for dimensions for UR669 and UR689 housings.

Length Code	Overall length mm (in)	Element Removal Clearance mm (in)	Empty Weight kg (lb)
20	897.1 (35.32)	442.7 (17.43)	88.9 (196)
40	1405.1 (55.32)	950.7 (37.43)	112.5 (248)

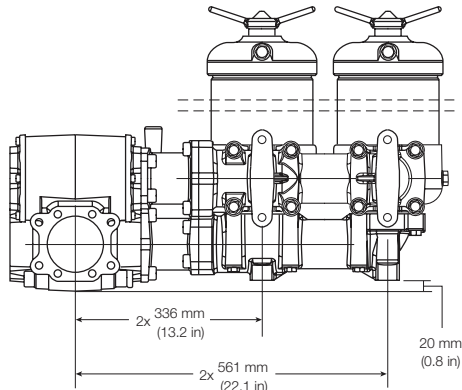

649 Duplex Mounting Dimensions

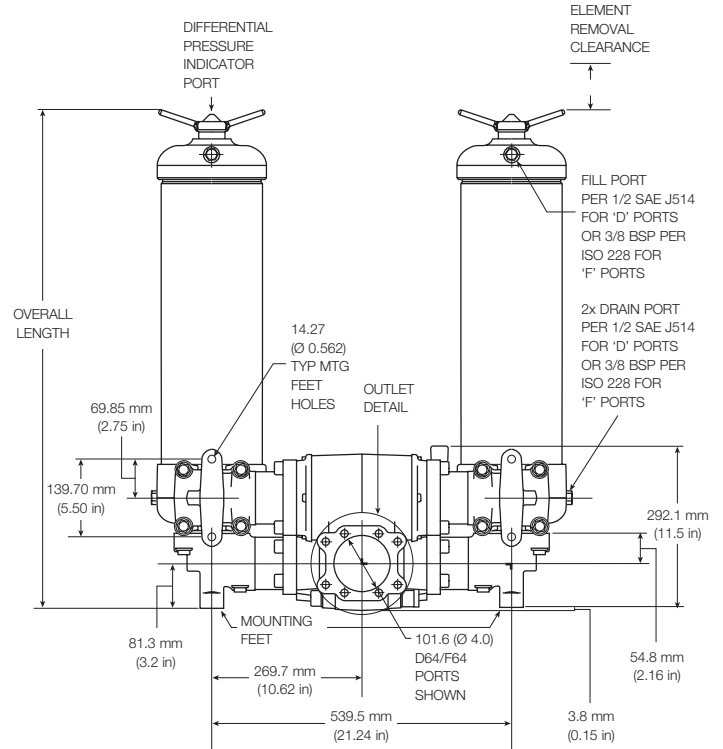
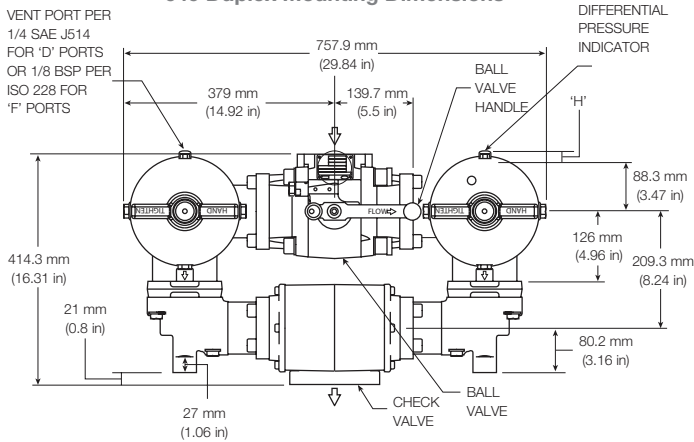

The equipment has been assessed in accordance with the guidelines laid down in The European Pressure Directive 97/23/EC and has been classified within Sound Engineering Practice S.E.P. Suitable for use with Group 1 and 2 fluids only. Consult Sales for other fluid gas group suitability.



25 Harbor Park Drive
 Port Washington, NY 11050
 +1 516 484 3600 telephone
 +1 800 289 7255 toll free US

Portsmouth - UK
 +44 (0)23 9233 8000 telephone
 +44 (0)23 9233 8811 fax
www.pall.com/contact

Visit us on the Web at www.pall.com

Pall Corporation has offices and plants throughout the world. For Pall representatives in your area, please go to www.pall.com/contact

Because of technological developments related to the products, systems, and/or services described herein, the data and procedures are subject to change without notice. Please consult your Pall representative or visit www.pall.com to verify that this information remains valid.

© Copyright 2019, Pall Corporation. Pall, and Athalon are trademarks of Pall Corporation. ® Indicates a trademark registered in the USA. Better Lives. Better Planet. and Filtration. Separation. Solution.sm are service marks of Pall Corporation.

