



Pall Corporation

UR629/649/669/689

## UR629/649/669/689 Series



EN UR629/649/669/689 Service Instructions

ENGLISH

service instructions

M&ESIUR629/649/669/689ENd

*Filtration. Separation. Solution.<sup>SM</sup>*

### 1 Specifications

#### Housing materials:

Head, tube, manifold

and check valve: Aluminium Alloy

Cover: Cast iron

#### Maximum operating pressure:

28 bar (400 psi)

#### Proof pressure:

42 bar (609 psi)

#### Minimum burst pressure:

145 bar (2100 psi)

#### Element collapse:

UE610 element 10 bard (150 psid) differential minimum

#### Operating temperature range:

-29° C to 120° C (-20° F to 250° F) with fluorocarbon seals for petroleum based and specified synthetic fluids

60° C (140° F) maximum in HWCF, water-oil emulsion or water glycol

#### Bypass valve setting options:

1.7 ± 0.3 bard (25 ± 5 psid) cracking pressure

4.5 ± 0.3 bard (65 ± 5 psid) cracking pressure

Non bypass

#### CAUTION:

Maximum surge flow should not exceed 1.3 times normal flow.

#### Seals:

Fluorocarbon

The actual operating conditions should be checked by the user to ensure that the element, housing and all seals are compatible with the fluid and application, and are within local safety codes. Please contact Pall or approved distributor if further information is required.

### 2 Receipt of equipment

The filter housing, and any optional equipment, are packed individually for assembly by the customer. Unpack carefully and ensure optional items are not mislaid in packaging to be discarded.

### 3 General sources of information

3.1 For dimensions, operating parameters, assembly/element part number, ordering information, notes, performance data and specifications refer to datasheet IMUR629EN.

3.2 This equipment has been assessed in accordance with the guidelines laid down in the European Pressure Directive 2014/68/EU and has been classified within sound engineering practice S.E.P. We hereby declare the equipment meets the requirements of article 4, paragraph 3, thus meeting the directive requirements. Under the provisions of this directive the filter assembly is suitable for use with group 2 fluids only.

3.3 Where under reasonably foreseeable conditions, including external fires, the allowable limits could be exceeded, suitable protective devices must be installed by the customer within the connecting fluid system.4.1 The filter can be installed in any attitude, but for ease of servicing, it is recommended that it be installed vertically with the filter tube and cover pointing upwards.

### 4 Installation of housing

4.1 The filter can be installed in any attitude, but for ease of servicing, it is recommended that it be installed vertically with the filter tube and cover pointing upwards.

4.2 The minimum clearance required for element removal of is as follows:

4.2.1 443mm or 17.5" for length 20 and 951mm or 37.5" for length 40 assemblies.

4.2.2 The UR629 Housing is supplied without a filter element. For element installation and servicing procedures, refer to Section 7.

4.3 Threaded differential pressure devices, when fitted, must be torque tightened to 30-33 ft/lb or 40-45 Nm. All visual indicators must be clearly visible.

**NOTE:** The UR629 housing is supplied with two machined differential pressure warning device ports, one fitted with a bleed plug, the other with a plastic shipping plug. If no differential pressure warning device is ordered, the shipping plug must be removed and replaced with a 'B' type blanking plug (P/N HA9000-P8-Kit Z) and torque tightened to 40 ft/lb /54 Nm.

**NOTE:** Never place the port plug in this port without first installing uniform size -014 O-ring in lower O-ring groove, otherwise a small bypass flow will result, allowing contaminant downstream of the filter element.

#### CAUTION:

Never operate the filter unless both warning device ports are sealed.

4.4 Mount the filter assembly using the four 14.3 mm diameter holes in the manifold assembly.

4.5 Use a check valve downstream of the filter if there is a possibility of reverse flow.

4.6 Install the filter housing using additional piping/valving to allow complete filter assembly bypass if filter maintenance is required without system shutdown.

#### CAUTION:

Reverse flow through filter element will cause damage.

**NOTE:** Piping supports should be provided as close as is practicable to the port connections in order to minimize external loads. This filter assembly must not be electronically isolated from the users earthing system. This filter assembly must be earthed by connecting the users earthing system to one of the inlet/outlet connections.

#### WARNING:

**USE FITTINGS OR ADAPTORS COMPATIBLE WITH PORTS SUPPLIED AS SHOWN BY PART NUMBER ON NAMEPLATE AND NOTED IN DATA SHEETS: USE OF INCORRECT FITTINGS OR ADAPTORS CAN CAUSE FILTER HOUSING OR MANIFOLD FAILURE RESULTING IN LOSS OF PRESSURE AND POSSIBLE SYSTEM FAILURE OR PERSONAL INJURY.**

4.7 Connect lines or hoses to housing inlet and outlet ports.

**NOTE:** Painting of the filter housing is optional. The coating on the filter housing is a suitable painting base. Cover the differential pressure warning device and nameplate if painting of the housing takes place.

### RETURN LINE FILTERS

- 4.8 Ensure the valves immediately upstream and downstream of the filter assembly are closed. Commission filter assembly as follows:

NOTE: For UR649, UR669 or UR689 units, the following procedure applies to each housing.

- (a) Ensure that drain and commuter valves are closed.
- (b) Open left hand housing vent port.
- (c) Open commuter valve (three full turns max) purge all air (16).
- (d) Position change-over valve to the left, to allow flow through left hand housing.
- (e) Bleed filter by opening the vent plug (10) on the cover (5) of the filter one and one half turns. Jog system and fill filter until all air bleeds through the plug (filter can be optionally filled using the fill port (12)), then tighten plug. Close commuter valve (16). Pressurize system fully and check for leaks; if leaks occur refer to section 5.
- (f) Open right hand housing vent port and commuter valve.
- (g) Open commuter valve (three full turns max) purge all air (16).
- (h) Position change-over valve to right, to allow flow through right hand housing. Close vent port when bubble free fluid issues from port and torque tighten to 12 ft/lb or 16 Nm. Close commuter valve (16).
- (i) Fully pressurize and check for leaks. If any leak is apparent shut down, depressurize and rectify leak before proceeding.
- (j) On completion of test sequence, position change-over valve to place selected housing on stream.

NOTE: Cover the visual warning device and nameplate if painting of the assembly takes place.

#### CAUTION:

**Failure to bleed the filter housing adequately will increase the dissolved air content of the system fluid which will shorten fluid life and may cause other problems in the system.**

### 5 Routine maintenance

- 5.1 Pall filters do not normally require special attention except for periodic monitoring of the differential pressure warning device. Schedule replacement of filter element every six months or sooner, and have ample supply of spare elements available.
- 5.2 If external leakage is noted, replace O-ring at leak. If leakage persists, check sealing surfaces for scratches or cracks; replace any defective parts. Body assembly is permanently assembled at the factory: do not attempt to disassemble the head (1), body tube (2), center post (3), change-over valve (14) or check valve (15).
- 5.3 Differential pressure devices actuate when the filter element (8) needs changing or because of high fluid viscosity in 'cold start' conditions. If 'cold start' conditions exist, see Section 6.2 and 6.3.
- 5.4 A dirty system can quickly plug a new filter element, especially with Pall high efficiency filter media. It may require one or two initial element changes to stabilize element life. If element life is short or differential pressure is excessive, filter may be undersized; refer to the sizing and selection section of the product literature or contact your local Pall representative.
- 5.5 Make sure element change labels are clean and undamaged. Replace illegible labels with the appropriate new labels.

#### CAUTION:

**Continued operation of 629 series bypass filters (valve options A, B and G), with differential pressure device actuated, can allow unfiltered flow downstream. Continued operation of 629 series non-bypass filters (valve options W or N may cause collapse or premature fatigue failure of the plugged filter element, which could allow contaminant and unfiltered flow downstream. Refer to element change instructions in section 7.**

### 6 Differential pressure devices

Reference should be made to product literature for dimensions, operating parameters, part numbering, ordering information and specifications.

- 6.1 Differential pressure devices actuate when the element needs changing or because of high fluid viscosity in 'cold start' conditions.
- 6.2 If visual indicator is fitted and actuates during 'cold start' (red button extends 5mm, 3/16"), reset by depressing the button when the normal operating temperature is reached. If indicator actuates after resetting, replace element.

NOTE: Option 'P' visual indicator has thermal lockout and manual reset. No signal below 0° C (32° F), signal above 27° C (80° F).

- 6.3 If the electrical switch actuates (e.g. red light comes on) during cold start, continue operating until the signal (red light) goes out as system warms to normal operating temperature. This feature can be used as 'warm up' indication in operating procedures. If the warning signal (red light) remains or appears when system is warm, replace the filter element.
- 6.4 Use of both positive indication (green light) and negative indication (red light for dirty element) is recommended to effectively monitor filter element life.

Electrical connections and ratings for all differential pressure switch options:

110 VAC	=	4A (inductive), 4A (resistive)
220 VAC	=	4A (inductive), 4A (resistive)
28 VDC	=	3A (inductive), 5A (resistive)
48 VDC	=	1A (inductive), 1.5A (resistive)
125 VDC	=	0.25A (inductive), 0.5A (resistive)

Maximum inrush - 24 amps.

Underwriter's lab. Inc. listed ratings of pressure switch (Microswitch) options are:

4 amps at 250 VAC
0.25 amp resistive at 220 VDC
0.50 amp resistive at 110 VDC

#### Electrical differential pressure switch operation:

When preset differential pressure is exceeded continuity switches from 'C' - 'A' to 'C' - 'B'.

When differential pressure decreases below the pre-set value, continuity returns to 'C' - 'A'.

**Figure 1 - Switch Circuit Diagram**

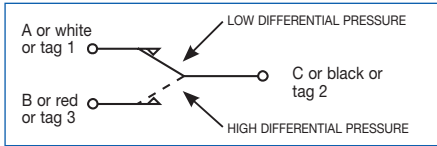

### 7 Filter element servicing

During servicing, the external surfaces of the filter assembly must be cleaned to remove any dust deposits.

Servicing must be conducted using suitable tools that do not present a hazard.

Servicing must not be carried out when a potentially explosive atmosphere is present.

#### CAUTION:

**Filter elements should be replaced upon indication or at specified intervals, six months maximum. Failure to change the element will cause the filter to go on bypass.**

Refer to Service Parts List (Section 10) for item numbers for applicable replacement element series. Remove and replace element as follows:

- 7.1 Open commuter valve (16) (three full turns max). Crack open off-line vent plug. Slowly open commuter valve to equalise pressure in the two sides of the housing. Close vent plug when bubble-free fluid issues from it. Close commuter valve (16).

NOTE: Change-over valve handle indicates the filter housing on stream.

#### WARNING:

**FAILURE TO CLOSE THE COMMUTER VALVE AND TO DEPRESSURISE THE FILTER HOUSING BEFORE SERVICING THE FILTER ELEMENT COULD RESULT IN EXPLOSIVE LOSS OF FLUID, DAMAGE TO EQUIPMENT AND POSSIBLE PERSONNEL INJURY.**

- 7.2 The off-line housing, now isolated from the system by the change-over valve, is depressurised by slowly venting through the vent plug (10). Open drain plug (11) and drain fluid into a suitable container. Discard fluid in accordance with local Health and Safety regulations. Close drain plug (11) and torque tighten to 12 ft/lb or 16 Nm.

NOTE: During element replacement some small internal leakage may be noted from the on-line filter housing.

#### WARNING:

**DO NOT ATTEMPT TO CLEAN OR RE-USE THE ELEMENT. ONLY USE GENUINE PALL REPLACEMENT FILTER ELEMENTS. USE OF SUBSTITUTE ELEMENTS MAY INVALIDATE PRODUCT WARRANTY.**

- 7.3 Manually unscrew cover handle and remove filter cover assembly (5) from tube (2). Remove element (8), if already fitted, and carefully inspect the surface for significant visible contamination. Normally no dirt should show but visible dirt or particles from the filter tube (2) interior and filter cover assembly (5) can be an early warning of

system component breakdown and can indicate potential failure. Discard both the element and its O-rings in accordance with local Health and Safety Procedures. The filter element is NOT CLEANABLE. Any attempt to clean the filter can cause degradation of the filter medium and allow contaminated fluid to pass through the filter.

#### WARNING:

**FAILURE TO REPLACE DAMAGED PARTS IN THE FILTER ASSEMBLY CAN CAUSE COMPONENTS IN THE HYDRAULIC SYSTEM TO FAIL OR DEGRADE IN THEIR PERFORMANCE.**

- 7.4 Inspect filter cover assembly (5) and bypass valves for possible damage or malfunction. Replace filter cover assembly if damage is observed. Remove any accumulated dirt from the filter tube interior and cover assembly being careful to prevent contaminant from entering the outlet and flowing downstream. DO NOT run the system without a filter element (8) installed. Check the O-rings (6) on the cover assembly (5) and centre post (3) are not damaged. Use the correct replacement filter element (8) part number called for on assembly nameplate.
- 7.5 Lubricate element O-ring seals with clean system fluid and push filter element (8) straight over the housing centre post. Ensure the cover assembly (5) and centre post (3) threads are clean and dry. Lightly lubricate the centre post threads, O-ring seal and cover assembly seals with clean system fluid. HAND TIGHTEN cover handle until cover assembly and tube are in contact. O-ring sealing is not improved by over tightening.

#### WARNING:

**DO NOT USE PIPE WRENCH, HAMMER OR ANY SIMILAR TOOL TO TIGHTEN COVER.**

- 7.6 Open housing vent plug (10). Open commuter valve (16) (three full turns max). Slowly open commuter valve to equalise the pressure between the two sides of the housing. Close vent plug when bubble free fluid issues from it. Close commuter valve and check for leaks. Filter housing is now ready for changeover when required. Close commuter valve (16).

NOTE: For UR649, UR669 and UR689 units, the above applies to each housing having elements replaced.

- 7.8 After element change ENSURE VISUAL DIFFERENTIAL PRESSURE WARNING DEVICE IS RESET BY PUSHING IN THE BUTTON; electrical devices are reset automatically. When system reaches normal operating temperature, check that electrical switch has not actuated and/or that visual warning button remains depressed. If visual indicator rises due to a cold start condition, reset again as per Section 6.

### 8 Fluid sampling

Optimum sampling to verify fluid condition can be achieved by the use of sampling adaptors installed in place of or in combination with the differential pressure device. This provides up and downstream 1/4-inch BSP parallel thread ports to be used for sampling. For more information consult Pall or your local Pall distributor. Pall offers a fluid contamination analysis service - consult the Pall sales office.

#### 9 Warranty, Limitation of Liability and Remedies

THERE IS NO WARRANTY OF MERCHANTABILITY OR FITNESS FOR ANY PARTICULAR PURPOSE WITH RESPECT TO ANY OF THE PRODUCTS. NOR IS THERE ANY OTHER WARRANTY EXPRESS OR IMPLIED, EXCEPT AS PROVIDED FOR HEREIN.

For a period of twelve months from the date of delivery from Seller or three thousand hours of use, whichever occurs first (the "Warranty Period", Seller warrants that products manufactured by Seller when properly installed and maintained, and operated at ratings, specifications and design conditions, will be free from defects in material and workmanship. By way of explanation and not limitation, the Seller does not warrant the service life of the filter element as this is beyond the Seller's control and depends upon the condition of the system into which the filter is installed. Seller's liability under any warranty is limited solely (in Seller's discretion) to replacing (FOB original ship point), repairing or issuing credit for products that become defective during the Warranty Period. Purchaser shall notify Seller promptly in

writing of any claims and provide Seller with an opportunity to inspect and test the product claimed to be defective. Buyer shall provide Seller with a copy of the original invoice for the product, and prepay all freight charges to return any products to Seller's factory, or other facility designated by Seller. All claims must be accompanied by full particulars, including system operating conditions, if applicable.

Seller shall not be liable for any product altered outside of the Seller's factory except by Seller or Seller's authorized distributor, and then, as to the latter, only for products which have been assembled by the distributor in accordance with Seller's written instructions. Nor shall Seller be liable for a product subjected to misuse, abuse, improper installation, application, operation, maintenance or repair, alteration, accident or negligence in use, storage transportation or handling.

In no event will Seller be liable for any damages, incidental, consequential or otherwise, whether arising out of or in connection with the manufacture, packaging, delivery, storage, use, misuse, or non use of any of its products or any other cause whatsoever.

#### 10 Parts List

List	Description	Catalog Number	Quantity
1	Filter Head	See Product Literature	2/4/6/8
2	Tube	See Product Literature	2/4/6/8
3	Centre Post	See Product Literature	2/4/6/8
4	Shell Assembly (Cage or Core Tube)	See Product Literature	2/4/6/8
5	Cover Assembly	See Product Literature	2/4/6/8
6	Seal Kit	See Table on Following Page	
7	Differential Pressure Indicator	See Product Literature	
8	Filter Element	UE610+++Z See Product Literature	2/4/6/8
9	Indicator Plug Ports	See Product Literature	
10	Vent Plug (1/4" SAE J514)	See Product Literature	2/4/6/8
11	Bleed / Drain Plug (1/2" SAE J514)	See Product Literature	4/8/12/16
12	Fill Plug (1/2" SAE J514)	See Product Literature	2/4/6/8
13	Mounting Bracket Kit	1129210	1
14	Change-over Valve including Commuter Valve	See Product Literature	1
15	Check Valve	See Product Literature	1
16	Commuter Valve	See Product Literature	

### 11 Seal Kit

Series	Seal Kit Part Number	Part	Description	Size (mm)	Location
R629 R649 R669 R669	UR629CSK(Z or H) UR649CSK(Z or H) UR669CSK(Z or H) UR669CSK(Z or H)	OR262	O-ring	177.4x3.53	Cover to Tube
		OR904	O-ring	8.9x1.83	Bleed Plug to Cover
		OR908	O-ring	16.36x2.20	Differential Pressure Indicator / Bleed Plug to Cover / Commuter Valve
		OR906	O-ring	11.47x1.911	Head to Bleed Plug
		OR152	O-ring	82.22x2.62	3-Way Valve and Cover Internals
		OR133	O-ring	45.70x2.62	Cover to Centre Post (lower)
		OR128	O-ring	37.77x2.62	Cover to Centre Post (upper)
		OR243	O-ring	104.37x3.53	Shell Assembly to Head
		OR014	O-ring	12.42x1.78	Differential Pressure Indicator / Commuter Valve
		OR261.5	O-ring	172.06x3.53	Head to Bowl
		OR232	O-ring	69.44x3.53	Head to Manifold / Manifold Adaptor to Manifold
		OR234	O-ring	77.57x3.53	Manifold Internals
		OR237	O-ring	85.32x3.53	Flange to 3-Way Valve
		OR241	O-ring	98.02x3.53	Check Valve
		OR249	O-ring	123.42x3.53	3-Way Valve
		OR210	O-ring	18.64x3.53	3-Way Valve
		OR108	O-ring	6.02x2.62	3-Way Valve
		OR008	O-ring	4.47x1.78	Commuter Valve
		G1/8	Seal Bonded	1/8"	Vent/Drain
		G3/8	Seal Bonded	3/8"	Vent/Drain
G1/2	Seal Bonded	1/2"	Vent/Drain		

Figure 2

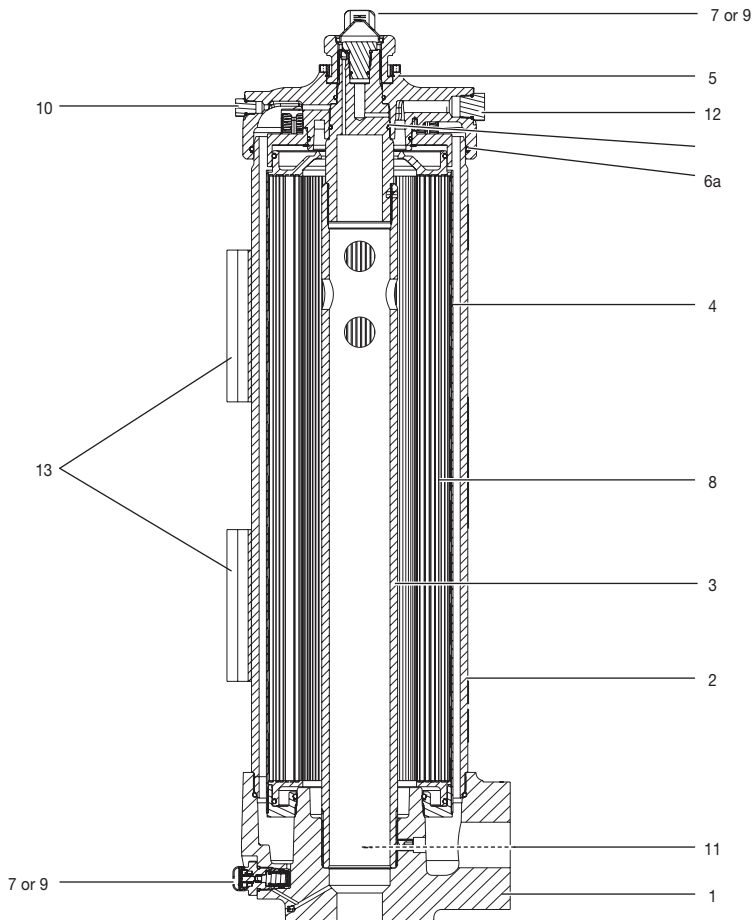
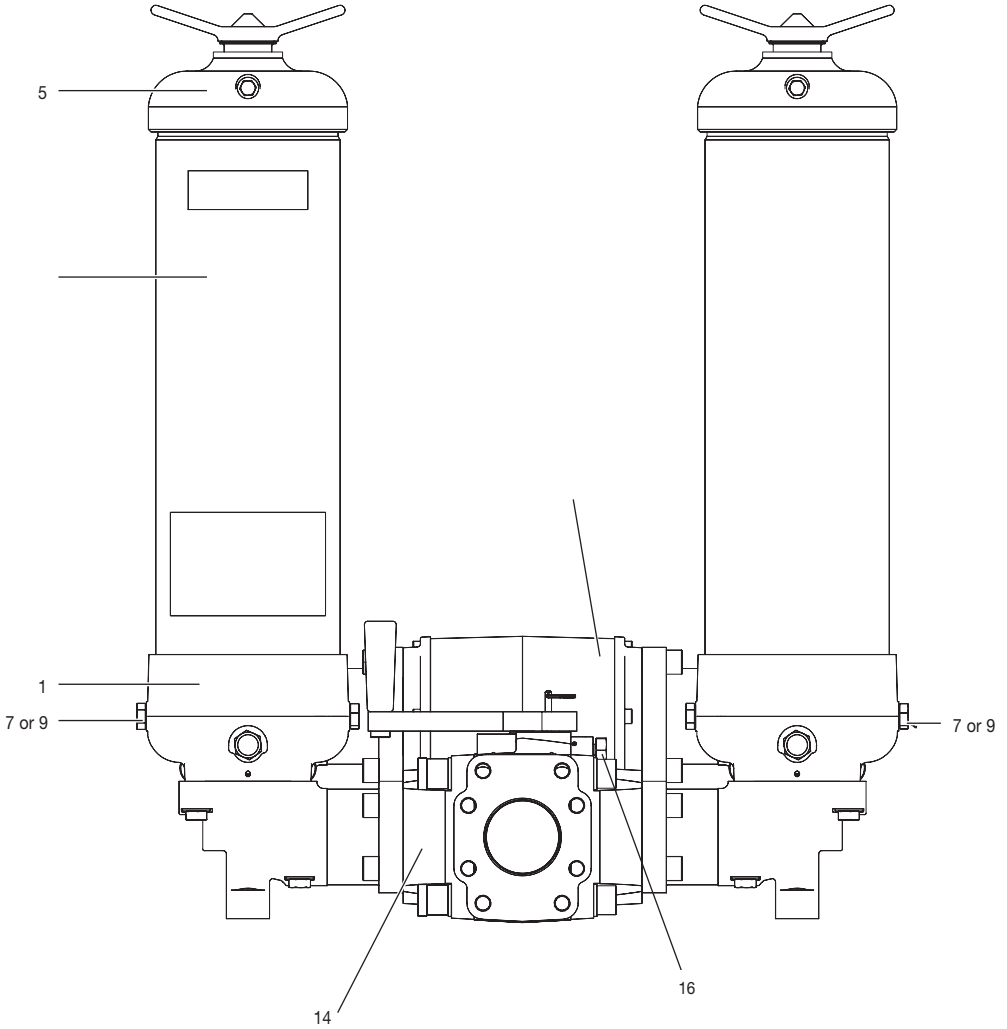
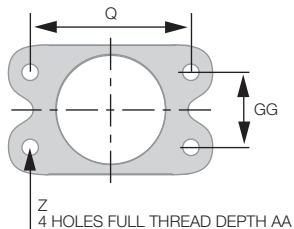

Figure 3





**Figure 4**



### Flange Connection Details

Flange Code	Nominal Tube Size	GG	Q	Z Thread	AA
D48	3"	2.438"	4.188"	5/8" - 11 UNC	1"
F48	3"	61.9 mm	106.4 mm	M16 x 2.00	28.5 mm
D64	4"	3.062"	5.125"	5/8" - 11 UNC	1.31"
F64	4"	77.8 mm	130.2 mm	M16 x 2.00	25.5 mm



## Pall Corporation

25 Harbor Park Drive  
Port Washington, NY 11050  
+1 516 484 3600 telephone  
+1 800 289 7255 toll free US

Portsmouth - UK  
+44 (0)23 9233 8000 telephone  
+44 (0)23 9233 8811 fax  
[www.pall.com/contact](http://www.pall.com/contact)



**Better Lives.  
Better Planet.™**

**Visit us on the Web at [www.pall.com](http://www.pall.com)**

Pall Corporation has offices and plants throughout the world. For Pall representatives in your area, please go to [www.pall.com/contact](http://www.pall.com/contact)

Because of technological developments related to the products, systems, and/or services described herein, the data and procedures are subject to change without notice. Please consult your Pall representative or visit [www.pall.com](http://www.pall.com) to verify that this information remains valid.

© Copyright 2019, Pall Corporation. Pall, , and Athalon are trademarks of Pall Corporation.

® Indicates a trademark registered in the USA. Better Lives. Better Planet. and Filtration. Separation. Solution.™ are service marks of Pall Corporation.