

## Description

Pall purifier systems enable the removal of molecular contamination to sub-parts-per-billion (ppb) levels from a variety of gases used in the semiconductor, photovoltaic, LED and display industries. They are well suited for applications such as bulk delivery and gas bottle filling.

- Flow rates up to 4,000 slpm (141 scfm)
- Purifier assemblies contain integral particle filters
- Isolation valves allow for easy replacement of individual assemblies
- Custom configurations available to meet specific customer requirements

## Specifications

<b>Purifiable Gases and Removal Efficiency</b>	<ul style="list-style-type: none"> <li>• See Table 1</li> </ul>
<b>Materials</b>	<ul style="list-style-type: none"> <li>• All wetted surfaces are electropolished 316L stainless steel (except for the purification material)</li> <li>• <math>\leq 0.25 \mu\text{m} / 10 \mu\text{in}</math> Ra internal surface finish</li> <li>• Housings meet or exceed VIM / VAR specifications</li> </ul>
<b>Particle Removal Rating<sup>1</sup></b>	<ul style="list-style-type: none"> <li>• <math>\geq 0.4 \mu\text{m}</math> (3 nm particle filter assemblies available as stand-alone units)</li> </ul>
<b>Housing Pressure Ratings</b>	<ul style="list-style-type: none"> <li>• Standard pressure: 1.7 MPa (250 psig)</li> <li>• High pressure: 20.7 MPa (3,000 psig)</li> </ul>
<b>Configurations</b>	<ul style="list-style-type: none"> <li>• Manifold contains 1 to 4 assemblies to accommodate flow rates up to 4,000 slpm (141 scfm)</li> <li>• Available with customer specific connections and components</li> </ul>
<b>Certifications</b>	<ul style="list-style-type: none"> <li>• ASME: Vessel is designed and manufactured in accordance with the ASME BPVC Section III, Div 1 and is U-stamped</li> <li>• PED: Available for most categories of gases</li> </ul>
<b>Leak Rating</b>	<ul style="list-style-type: none"> <li>• Assemblies are 100% helium leak tested to <math>1 \times 10^{-9}</math> atm-cm<sup>3</sup>/s</li> </ul>

<sup>1</sup> Particle rating is based on laboratory testing with NaCl aerosol.



## Nominal Dimensions

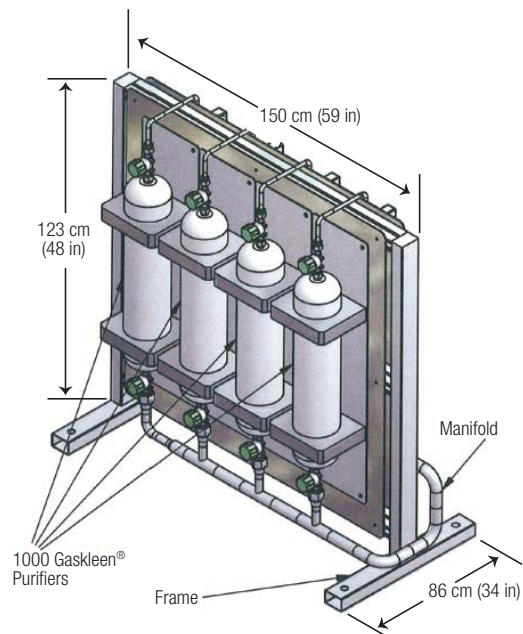

**Table 1: List of Purifiable Gases**

Gas	Purifier Material Code	Effluent Specification <sup>2</sup>
Nitrogen, argon, helium, xenon, krypton, neon	INP	<1 ppb H <sub>2</sub> O, O <sub>2</sub> , CO <sub>2</sub> and CO
Silane, hydrogen, methane, ethane, cyclopropane, propane, dimethyl ether	SIP	<1 ppb H <sub>2</sub> O, O <sub>2</sub> , CO <sub>2</sub> and CO
Carbon monoxide	SIP	<1 ppb H <sub>2</sub> O, O <sub>2</sub> , CO <sub>2</sub> , Ni(CO) <sub>4</sub> and Fe(CO) <sub>5</sub>
Fluoromethane, difluoromethane, trifluoromethane, tetrafluoroethane, pentafluoroethane, heptafluoropropane, carbon tetrafluoride, perfluoropropane, perfluorocyclobutane, hexafluoroethane	FCP	<1 ppb H <sub>2</sub> O, O <sub>2</sub> , and CO <sub>2</sub>
Germane	GEH4P	<1 ppb H <sub>2</sub> O, O <sub>2</sub> , and CO <sub>2</sub>
Sulfur hexafluoride	SF6P	<1 ppb H <sub>2</sub> O, O <sub>2</sub> , and CO <sub>2</sub>
Air, carbon dioxide, oxygen, nitrous oxide	OXF	<10 ppb H <sub>2</sub> O
Boron trichloride, chlorine, trichlorosilane, dichlorosilane	CLXP	<100 ppb H <sub>2</sub> O
Hydrogen chloride	HCLP	<15 ppb H <sub>2</sub> O
Hydrogen bromide	HBRP	<50 ppb H <sub>2</sub> O
Photolithography clean dry air	CDAP	<1 ppb H <sub>2</sub> O, <1 ppb organics (as C <sub>4</sub> ), <10 ppt acid gases (as SO <sub>2</sub> ), <15 ppt basic gases (as NH <sub>3</sub> ), <1 ppt refractory compounds (as HMDSO)

<sup>2</sup> Gas specific data available upon request.

## Part Numbers/Ordering Information

Contact Pall Microelectronics



Pall Corporation

### Microelectronics

25 Harbor Park Drive  
 Port Washington, NY 11050  
 +1 516 484 3600 telephone  
 +1 800 360 7255 toll free US

### Visit us on the Web at [www.pall.com/micro](http://www.pall.com/micro)

Pall Corporation has offices and plants throughout the world. For Pall representatives in your area, please go to [www.pall.com/contact](http://www.pall.com/contact).

Because of technological developments related to the products, systems, and/or services described herein, the data and procedures are subject to change without notice. Please consult your Pall representative or visit [www.pall.com](http://www.pall.com) to verify that this information remains valid. Products in this document may be covered by one or more patents, including US 7,465,692.

© Copyright 2018, 2014, 2012, Pall Corporation. Pall, , and Gaskleen are trademarks of Pall Corporation. ® Indicates a Pall trademark registered in the USA. **Filtration. Separation. Solution.<sup>SM</sup>** is a service mark of Pall Corporation.