



Pall Corporation

Pall Aria™ Integrated MF/RO Systems

Filtration. Separation. Solution.SM

Pall Aria™ Integrated MF/RO Systems for Cost-Effective Treatment of Plant Make-Up Water

Water scarcity resulting from man-made and natural influences such as growing populations, expanding industrial usage, climate change and drought, is a challenge faced by water producers and users worldwide. High-pressure reverse osmosis (RO) and nanofiltration membrane systems have been used for many years to remove dissolved substances from water, with mixed success. The pretreatment typically used with these processes—conventional (sand) filters with coagulation, followed by cartridge filters—has proven to be ineffective and expensive in the long-term. On the other hand, when microfiltration is used to pre-treat the water, spiral-wound RO membrane systems are a reliable and cost-effective alternative that has become the technology of choice for many plant make-up water applications.

In addition to choosing the most effective technology, industrial high-purity water users are concerned with maximizing production volume by ensuring ongoing operation of the make-up water system. If the system comprises components from several vendors, the troubleshooting process can take much longer. **When the components of the make-up system are sourced through a single vendor, the responsibility is clear, and service and support are optimized.**



An Integrated Make-Up Solution from Pall, the Global Leader in Filtration and Separations

To meet the need to produce pure water for make-up, Pall Corporation offers complete, packaged, spiral-wound RO and nanofiltration systems, fully integrated with our proven microfiltration membrane technology for pretreatment. As the global leader in filtration solutions, Pall has been a trusted supplier to municipalities, industries and government for over 60 years. Pall’s water processing team applies its expertise in process design, membrane science, system engineering, and manufacturing to deliver truly optimized make-up water systems.

Major MF and RO Components

Two major components comprise the Pall Aria™ MF/RO integrated system: the Pall Aria microfiltration membrane system for pretreatment, and an RO membrane system. Ion exchange may also be used if necessary. Both systems are constructed from standard “building blocks”—prefabricated skids of valve and module racks.

- **The Pall Aria microfiltration membrane system—**removes suspended solids from source water during the pretreatment process. Pall Aria microfiltration

membranes are the most robust in the industry, with the longest warranty. In fact, a Pall customer in California with more than 700 modules experienced fiber breakage of only 1 in 3,073,400 over a 40-month period.* More than 300 filtration systems using the membrane technology incorporated in Pall’s systems have been sold worldwide.

- **A Pall reverse osmosis membrane RO system—**captures dissolved salts and other impurities from pretreated water with spiral-wound RO technology, the industry standard for RO systems. Spiral-wound RO modules capitalize on an extremely high ratio of filter area to hold-up volume. With feedwater that is optimally pre-treated, these modules allow the greatest output of treated water with the lowest energy use.

Recover Energy From Your Process

After analyzing the energy requirements and costs for your specific process, Pall will recommend and implement a state-of-the-art device to recover energy from the pressured brine stream. By recycling this energy to power the pumps on the RO system, your cost of water production will be reduced.

* Based on the CalWater, Bakersfield, CA installation.

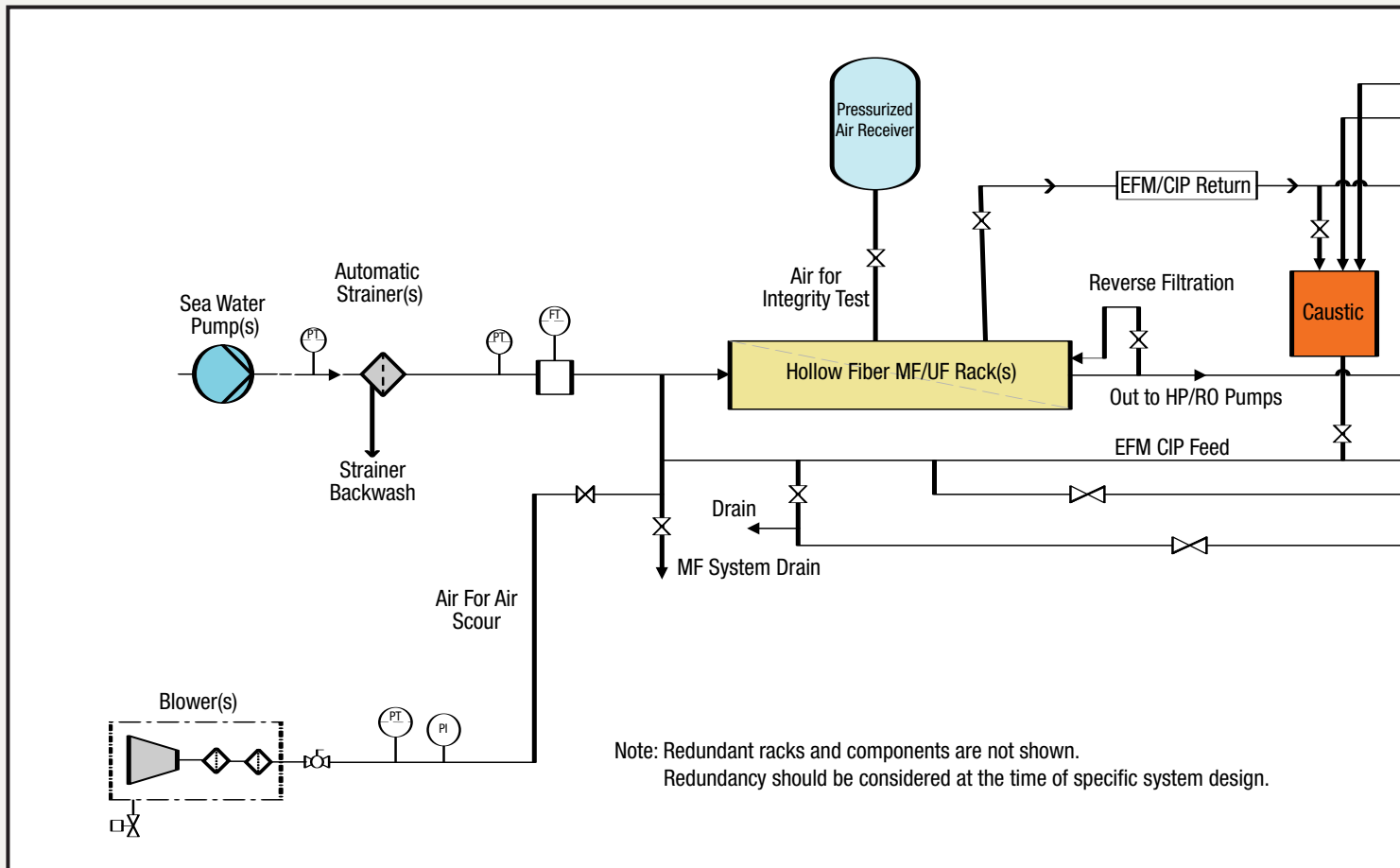

Figure 1 — Simplified process flow diagram: Pall Aria™ Integrated MF/RO System

Reduce Your Risk and Long-Term Costs

In addition to the energy conservation benefits of our MF/RO solution, Pall provides you with the following cost-saving, efficiency, and risk-reduction advantages.

- **Smaller footprint**—Membrane systems have a smaller footprint and lower long-term costs than conventional filtration technologies. The pre-engineered design and assembly of the integrated MF/RO system enables you to reduce space requirements, thereby reducing facility costs.
- **Lower overall cost of water production**—Pall sales and process engineers are available to provide estimates for capital and operating costs to enable you to derive and evaluate the overall cost of water using a Pall integrated MF/RO system. We're convinced that our system will realize cost savings over systems supplied by others who are not filtration experts. Our experienced engineers design and package systems that optimize operations and maintenance.
- **Longer lifespan of the RO membranes**—By pretreating raw make-up water with microfiltration membranes, Pall's integrated system exposes the

RO membranes to a lower volume of particulate matter. This protective capability reduces the number of membrane cleanings, increases efficiency, and prolongs the life and value of the RO system.

- **Redundant components maximize uptime**—The MF and RO system modules are redundant, enabling the integrated system to maximize uptime for critical water delivery applications.
- **Lower chemical use**—There are no pre-treatment chemicals to mix, feed, and adjust when feedwater conditions change.
- **Long-term reliable operation**—By developing a make-up process that is tailored to your feed water characteristics and treatment needs, Pall will ensure the long-term, reliable operation of your MF/RO system. Further, your system can be matched with a customized service plan.
- **Single point of responsibility**—With a single supplier for your entire make-up system, potential problems will be addressed more rapidly, thereby reducing the potential risk of downtime and reduced production.

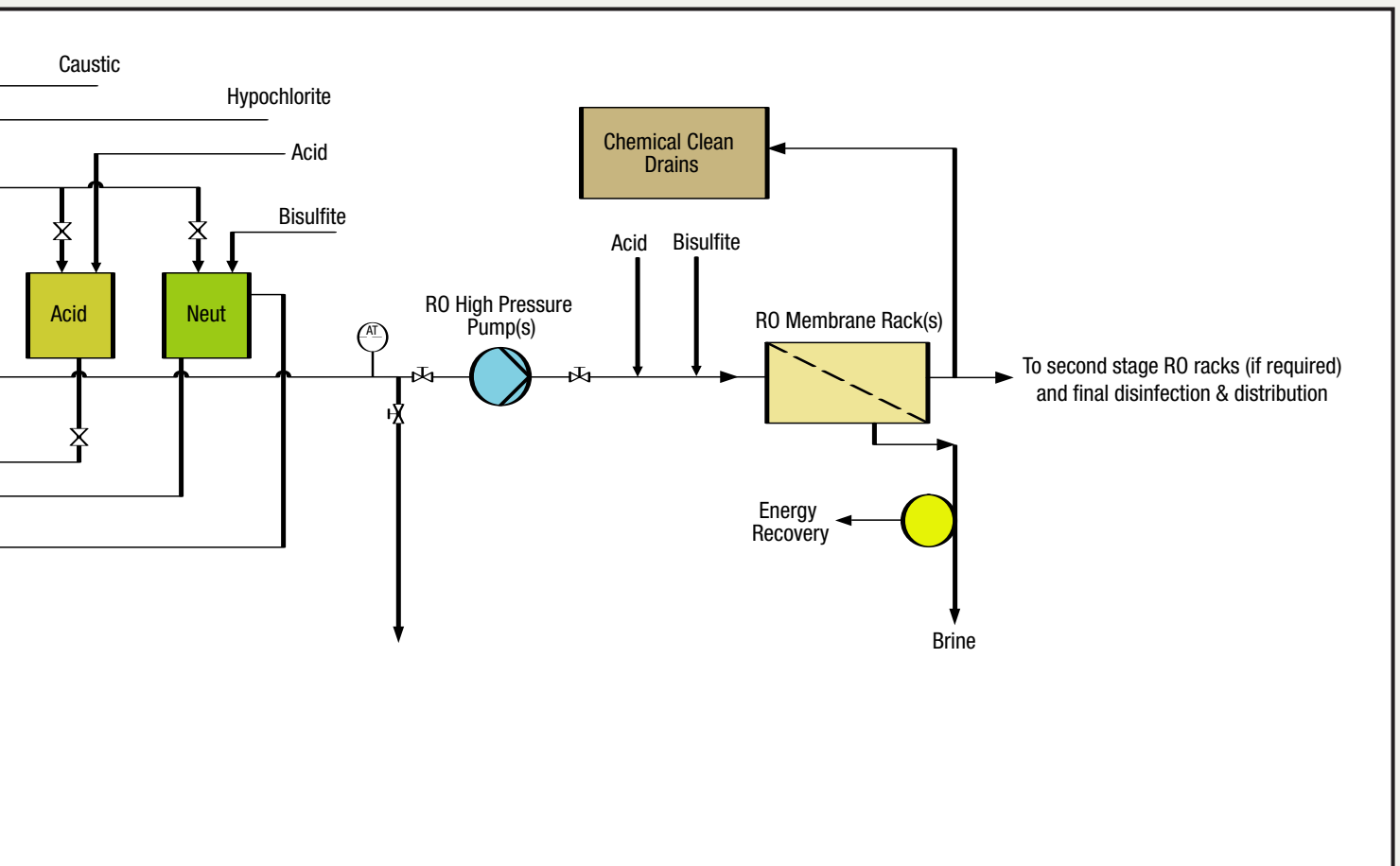

Technical and Support Services for Long-Term Reliability

To help ensure trouble-free operation of your system, Pall offers a comprehensive portfolio of technical support services. These services can help you:

- Gain technical expertise without adding head-count
- Realize optimized system performance and product quality
- Increase system reliability
- Enjoy cost-effective operation and maintenance

Your Pall representative will help you choose one or more of the following services to support your MF/RO integrated system:

- 24/7 Service Support
- CIP (Clean-In-Place)
- Commissioning and Start-up
- Emergency Service
- Inspection and Maintenance
- Membrane Cleaning Study
- Operation And Maintenance (O&M)
- Process Audit
- Process Consulting
- Process Monitoring Systems
- Remote Monitoring
- Spare Parts Inventory Management
- System Optimization
- Technical Support
- Training
- Water Analysis

How to Get Started

Pall's integrated MF/RO system combines the strengths of Pall's membrane microfiltration technologies, engineering and technical expertise, and comprehensive support for high-yield production of pure water for plant make-up. Please contact your local Pall representative for more information and a free analysis of your feedwater and treatment requirements.



Power Generation

25 Harbor Park Drive
Port Washington, NY 11050

1.888.873.7255 toll free
516.484.3600 phone
516.484.0364 fax

Visit us on the Web at www.pall.com

Pall Corporation has offices and plants throughout the world in locations including: Argentina, Australia, Austria, Belgium, Brazil, Canada, China, France, Germany, India, Indonesia, Ireland, Italy, Japan, Korea, Malaysia, Mexico, the Netherlands, New Zealand, Norway, Poland, Puerto Rico, Russia, Singapore, South Africa, Spain, Sweden, Switzerland, Taiwan, Thailand, United Kingdom, United States, and Venezuela. Distributors are located in all major industrial areas of the world.

© Copyright 2007 Pall Corporation. Pall, , and Pall Aria are trademarks of Pall Corporation.
® Indicates a Pall trademark registered in the USA. *Filtration. Separation. Solution.SM* is a service mark of Pall Corporation.

Filtration. Separation. Solution.SM

PGMFROENa