

Pall Portable Filtration Unit PFUDC Series Diesel Fuel

Features

- Pall Ultipleat® SRT filters for superior fluid cleanliness and contamination control
- Pall PhaseSep® coalescers for efficient liquid removal and improved fluid quality
- Compact and portable unit, low noise level
- Easy element removal from the filter housing
- Flows up to 13 L/min (3.4 US gpm)
- Pressures up to 10 bar (150 psi)
- Inlet connection: 1 1/2" BSP female
- Outlet connection: 1/2" BSP female

Notes and Specifications Filtration Unit

Power Consumption:	0.25 kW
Supply Power:	Single phase, 230 V, 50 Hz
Control Box:	On/Off switch
Approximate Dry Weight:	75 kg
Fluid Compatibility:	Fluorocarbon elastomer seals. Compatible with petroleum based fluids, synthetics and mineral oils
Viscosity Range:	10 - 320 cSt
Temperature Range:	-10°C to 70°C (14°F to 160°F)
Pump Pressure	
Relief Valve:	10 bar (150 psi)
Maximum Negative Pressure for Inlet:	0.4 bar (6 psi)
Materials of Construction:	Aluminum, 316L SS
Ultipleat SRT Element Construction:	Inorganic fibers impregnated and bonded with epoxy resins, polymer endcaps, anti-static media design.

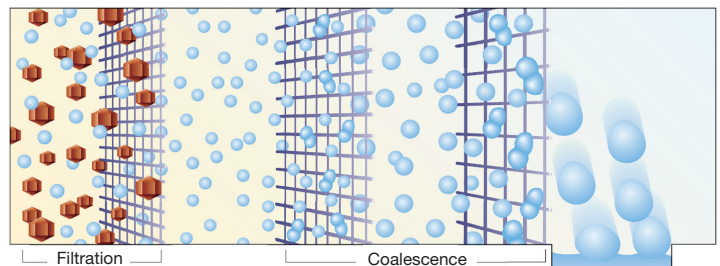
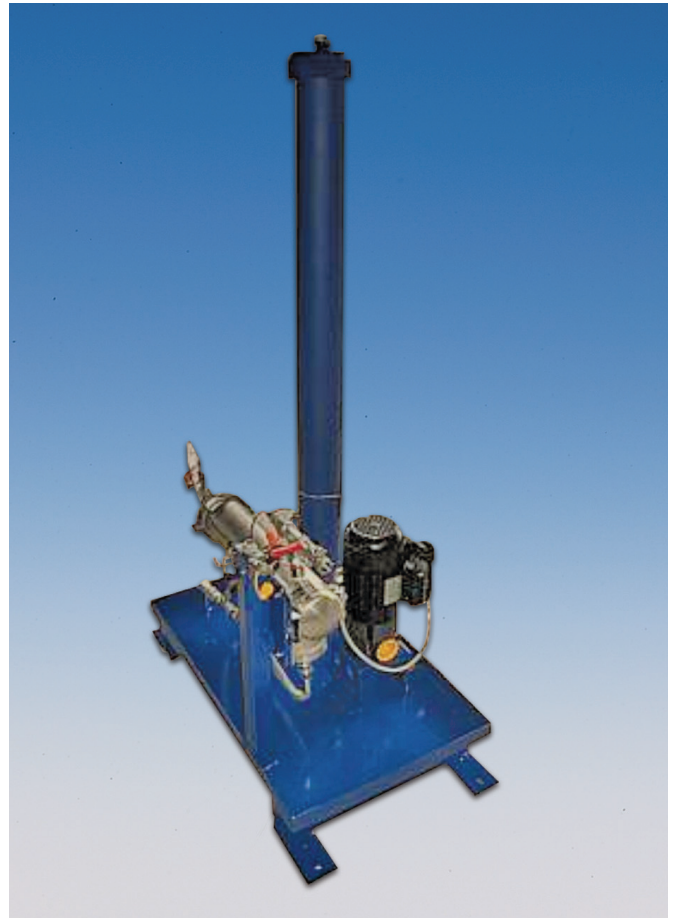

Filtration: solid particles are removed from the fuel stream by the Ultipleat SRT filter.

Coalescence: small droplets are merged into larger ones as they pass through several layers of filter media in the PhaseSep coalescer.

Separation: gravity takes effect, the large droplets are separated from the product fluid stream.

Technical Information

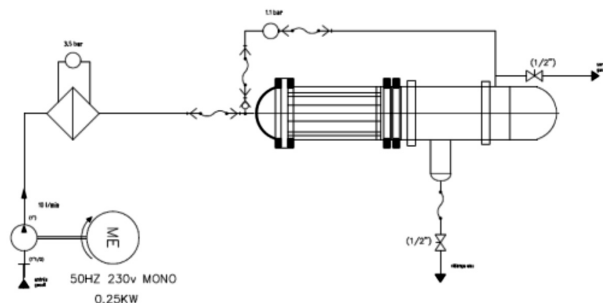
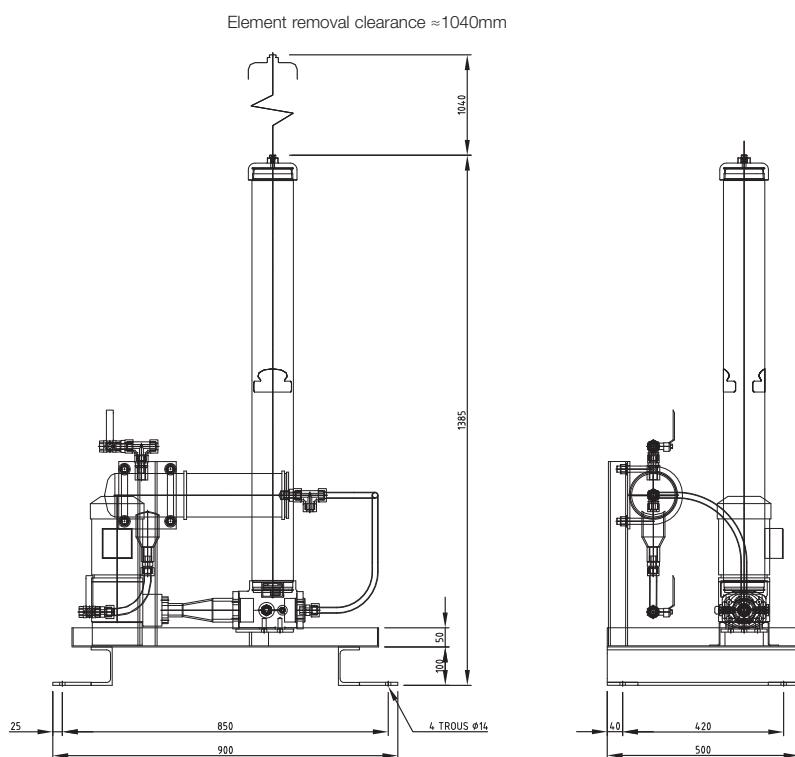

The contaminated fuel is passed through the filtration unit via the pump.

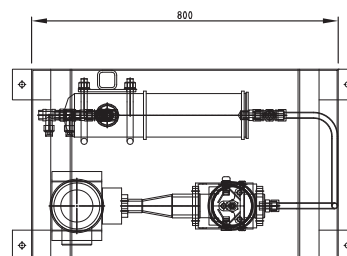

Ordering Information

Filtration Unit Part Number = PFUDC
 Filter Element Part Number = UE 319 AN 40 Z
 PhaseSep Coalescer Part Number = LCS06H2AH

Code	$\beta_{x(c)} \geq 1000$ based on ISO 16889	CST Rating*
AZ	3	08/04/01
AP	5	12/07/02
AN	7	15/11/04
AS	12	16/13/04
AT	22	17/15/08

*CST: Cyclic Stabilization Test to determine filter rating under stress conditions, based on SAE ARP4205



Pall Corporation

Power Generation

25 Harbor Park Drive
 Port Washington, NY 11050
 +1 516 484 3600 telephone
 +1 888 873 7255 toll free US

Paris – France
 +33 (0)1 30 6138 00 telephone
 +33 (0)1 30 6122 61 fax



Visit us on the Web at www.pall.com

Pall Corporation has offices and plants throughout the world. For Pall representatives in your area, please go to www.pall.com/contact.

Because of technological developments related to the products, systems, and/or services described herein, the data and procedures are subject to change without notice. Please consult your Pall representative or visit www.pall.com to verify that this information remains valid. Products in this document may be covered by one or more of the following patent numbers: EP 667,800; EP 982,061; EP 1,380,331; US 5,543,047; US 5,690,765; US 5,725,784; US 6,113,784; US 7,083,564; US 7,318,800.

© Copyright 2014, Pall Corporation. Pall, (PALL), PhaseSep and Ultipleat are trademarks of Pall Corporation. ® indicates a trademark registered in the USA. **BETTER LIVES. BETTER PLANET.** and **Filtration. Separation. Solution.SM** are service marks of Pall Corporation.