



Pall Corporation

Ink Jet Capsule



Pall Ink Jet Team



Filtration. Separation. Solution.SM

IJ 1495c



Optimised Ink Jet filter capsule ensures clean ink and protection of the print head

The Pall® Ink Jet capsule and UV resistant Ink Jet capsule range of disposable capsule filters have been developed to offer a high level of protection for the print heads in ink jet printing machines.

The success of the Ink Jet capsule product is attributed to its compact design and excellent filtration performance. The UV resistant Ink Jet capsule filter combines these characteristics with an opaque capsule design to reduce the risk of UV-sensitive fluids being prematurely cured inside the filter.

Description

- The **Pall** Ink Jet capsule and UV resistant Ink Jet capsule have an all-welded construction ensuring maximum strength and compatibility.
- No binders, glues or mold release agents are employed.
- Both the **Pall** Standard and UV resistant Ink Jet capsule filters incorporate **Pall** polypropylene Profile® Star and **Profile II** media (refer to Pall publication PSD 1769 and PSD 1770 for further details).
- Encapsulated filter which ensures a clean and safe environment.

Convenience – Ease of use

- Minimal hold up volume of fluids ensures minimum wastage.
- Small, light, and easy to connect.
- All-polymeric construction allows incineration for easy and economic disposal.
- Inlet and outlet connections are an integrally moulded part of the capsule, thus reducing the number of seals required.

Features

- Black capsule (UV resistant Ink Jet capsule only)
- Multi connections
- No binders, glues or mold release agents are employed
- Low hold up volume
- Encapsulated filter

Advantages

- Offers protection from UV light
- Versatile
- Low extractables
- Minimal product loss during changeout
- Ensures easy fitment

Benefits

- Prevents curing of the UV fluids during filtration
- Suits all printers
- Good compatibility, safe and economic to dispose
- Economical to filter and less waste
- Maximum user security



Technical Information

Materials of Construction

Filter Media	Polypropylene
Capsule	Polypropylene

Operating Characteristics ⁽¹⁾

Maximum Allowable Pressure	94 psig / 6.5 barg
Maximum Allowable Temperature	50°C / 122°F

⁽¹⁾ In compatible fluids which do not soften, swell or adversely affect the filter or materials of construction. Maximum ΔP based on core collapse data.

Nominal Dimensions

Length of Capsule	2.32" / 59.0mm
External Diameter	3.05" / 77.5mm
Effective External Diameter	3.35" / 85.0mm

Seal of Quality

The **Pall** Ink Jet capsule and UV resistant Ink Jet capsule filters are manufactured to a very high standard of quality assurance and cleanliness.

Manufactured in accordance to BS EN ISO 9001 : 2000

Typical Flow Rate versus Differential Pressure ⁽²⁾

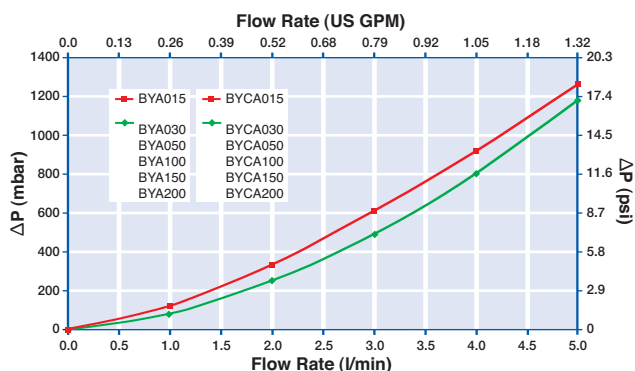

⁽²⁾ For fluids of 1 cP viscosity. As a general guide, for other viscosities, multiply differential pressure by viscosity in cP.

Dimensional Drawing

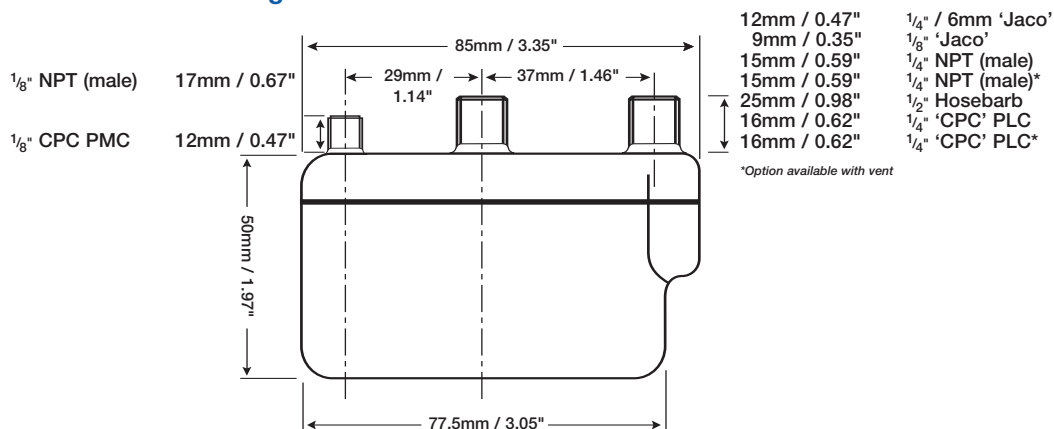



Ordering Information

(This is a guide to the part numbering structure only. For availability of specific options, please contact Pall)

B Y
 Table 1 Table 2 Table 3 Table 4

Table 1

Code	UV Capsule
No Code	Standard
C	UV resistant (black)

Table 2

Code	Removal Rating ⁽³⁾
Profile Star	
A010	1µm ⁽⁴⁾
A015	1.5µm
A030	3µm
A050	5µm
A100	10µm
A150	15µm
A200	20µm

⁽³⁾ Based on the modified OSU-F2 test in water.

⁽⁴⁾ For further info on this grade please contact Pall

Table 3

Code	Connector Option
No Code	1/4" 'Jaco'
2	1/8" 'Jaco'
3	1/4" NPT ⁽⁵⁾
6	1/2" Hosebarb
8	'CPC' PLC Series ⁽⁵⁾

⁽⁵⁾ Available with optional vent

Table 4

Code	Seal Option ⁽⁶⁾
J	EPR

⁽⁶⁾ Code 8 connector option only

Table 5

Code	Vent Option
No Code	No vent
4	1/8" NPT ⁽⁷⁾
7	1/8" 'CPC' PMC Series ⁽⁸⁾

⁽⁷⁾ Connector Option 3 only

⁽⁸⁾ Connector Option 8 only



Pall Microelectronics

New York - USA
 800.360.7255 toll free
 +1 516 484 5400 telephone
 +1 516 625 3610 fax

Portsmouth - UK
 +44 (0)23 9230 2374 telephone
 +44 (0)23 9230 2509 fax
 processuk@pall.com

Visit us on the web at www.pall.com

Pall Corporation has offices and plants throughout the world in locations including: Argentina, Australia, Austria, Belgium, Brazil, Canada, China, France, Germany, Hong Kong, India, Indonesia, Ireland, Italy, Japan, Korea, Malaysia, Mexico, the Netherlands, New Zealand, Norway, Poland, Puerto Rico, Russia, Singapore, South Africa, Spain, Sweden, Switzerland, Taiwan, Thailand, United Kingdom, United States, and Venezuela. Distributors are located in all major industrial areas of the world.

Because of developments in technology these data or procedures may be subject to change. Consequently we advise users to review their continuing validity annually. Part numbers quoted above are protected by the Copyright of Pall Europe Limited.

PALL, Pall and Profile are trade marks of Pall Corporation.

Jaco is a trade mark of Jaco Manufacturing Company.

CPC is a trade mark of Colder Products Company.

Part numbers quoted above are protected by the Copyright of Pall Europe Ltd.

® indicates a Pall trade mark registered in the USA.

Filtration, Separation, Solution is a service mark of Pall Corporation.

©2005, Pall Europe Limited.